

# 三菱工業用ミシン部品カタログ

## MITSUBISHI Industrial Sewing Machine Parts Catalog

Model  
PLK-2520

### 目次

### INDEX

Page

1. 本 体 関 係	4
2. 天 秤 ・ 針 棒 関 係	6
3. 上 軸 ・ 縦 軸 関 係	8
4. 押 工 関 係	10
5. 上 部 送 り 関 係	12
6. 下 軸 ・ カ マ 関 係	14
7. メ ス ( 糸 切 り ) 関 係	16
8. カ ム 軸 取 付 台 関 係	18
9. ピ ッ カ ー お よ び 糸 切 り 作 動 関 係	20
10. 検 出 器 関 係	22
11. 給 油 関 係	24
12. 付 属 品 箱	26
13. 付 属 品	28
W, X, Y. テ ー ブ ル 関 係	32
P. 外 押 え 関 係	36
T. テ ー ブ ル 本 体 関 係	40
A. モ ー ト ル 関 係	46
C. 制 御 関 係	52
N. エ ャ ー 配 管 関 係	54
F. 付 属 品 ・ オ プ シ ョ ン 関 係	56

Arm bed & its accessories.....	4
Thread take-up lever & needle bar mechanism.....	6
Arm shaft & vertical shaft mechanism.....	8
Presser bar lifting mechanism.....	10
Upper feed mechanism.....	12
Hook shaft & hook mechanism.....	14
Knife actuating mechanism.....	16
Cam shaft bracket.....	18
Picker & underded trimmer actuator.....	20
Synchronizer mechanism.....	22
Oil lubrication mechanism.....	24
Accessory box.....	26
Accessories.....	28
X,Y.Table mechanism.....	32
Work holder mechanism.....	36
Table mechanism.....	40
Motor mechanism.....	46
Controle mechanism.....	52
Air mechanism.....	54
Accessories its option parts.....	56

 三菱電機株式会社

198307

本体関係

ARM BED & ITS ACCESSORIES

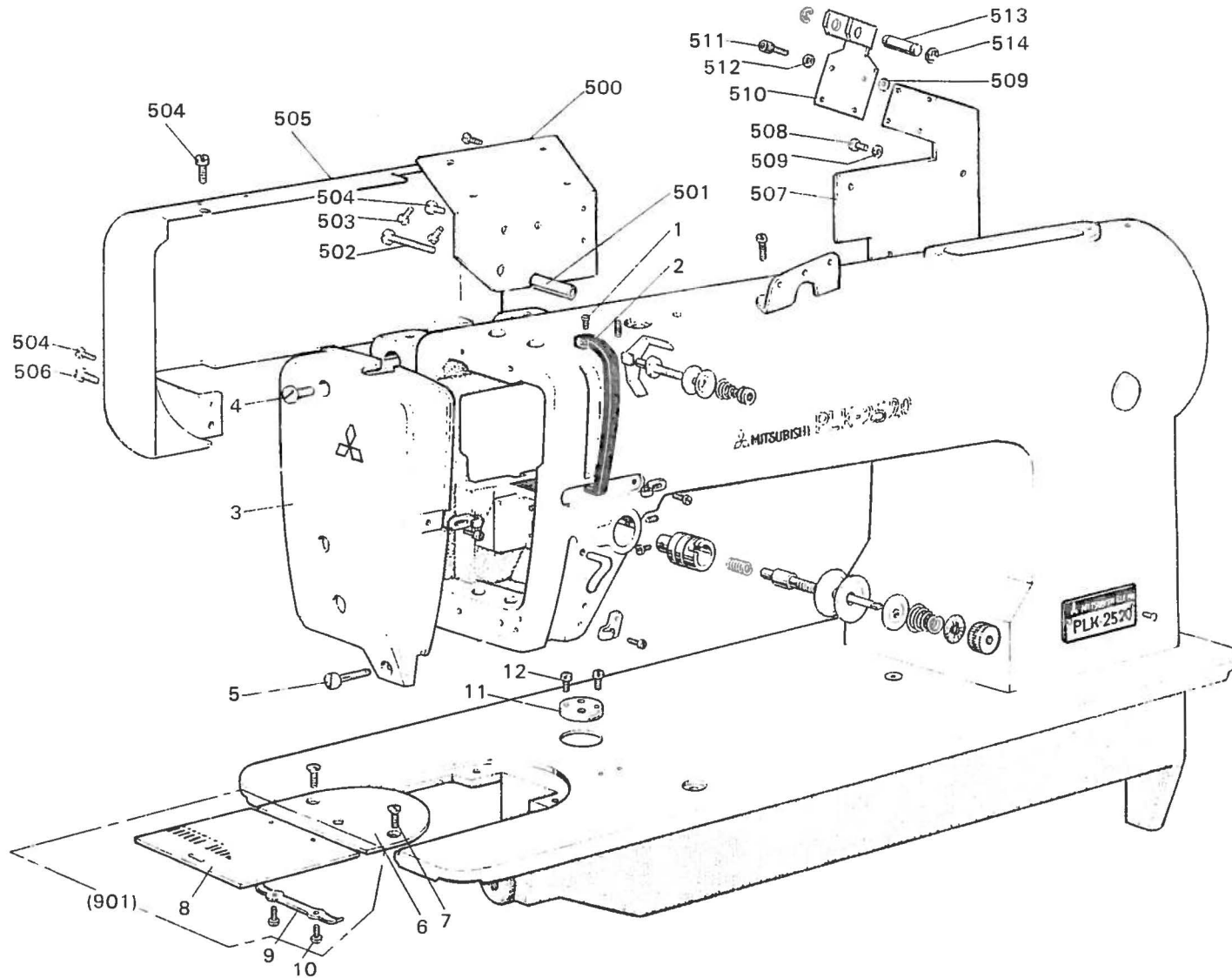

本体関係  
ARM BED & ITS ACCESSRIES

Fig. No.	部品コード Parts No.	資材コード Ref. No.	部 品 名	Description	使用 個数 Amt. Req.	共通部品 Common Parts					
						IDY-349-22-8Z	PV-2000-349	PLK-2520			
1	M9 1107 002	W500092H01	平 ネ ジ 11 64(40)×5.5	Screw 11 64(40)×5.5	1						
2	MF 17B0 584	W458150H01	天 坪 カ バ ー	Thread take-up cover	1						
3	MG 30A1 830	W344935H01	面 板	Face plate	1						
4	M9 1070 003	S 516131H01	丸 平 ネ ジ 5 32(40)×30	Screw 5 32(40)×30	1						
5	M9 1106 003	W500369H01	丸 平 ネ ジ 11 64(40)×20	Screw 11 64(40)×20	1						
6	MV 30A0 101	W349841H01	針 板 針穴φ3	Needle plate	1						
7	M9 1106 011	W502948H01	丸 皿 ネ ジ 11 64(40)×8	Screw 11 64(40)×8	2						
8	MG 30A0 470	B 419208H02	ス ベ リ 板	Slide plate	1						
9	MF 10A0 471	B 419207H01	スベリ板バネ	Spring for slide plate	1						
10	M9 0604 002	B 509070H01	平 ネ ジ 3 32(56)×2.2	Screw 3 32(56)×2.2	2						
11	MG 30A1 601	W483491H01	取 付 板	Cloth guide plate	1						
12	M9 1107 002	W500092H01	平 ネ ジ 11 64(40)×5.5	Screw 11 64(40)×5.5	2						
901	MF 10E0 470	W461757G02	スベリ板(組)	Slide plate complete	1						
500	MS 05A0 826	BA140D826H01	取 付 板 (PPB)	plate(PPB)	1						
501	MV 30A0 482	BE702D608H01	ス リ ー ブ	Sleeve	1						
502	M9 2051 003	W502313H01	マルヒラネジ 5 16(24)×26	Screw 5 16(24)×26	1						
503	M9 0301 037	S902N032P06	SW-PW付Pナベネジ M3×6	Screw M3×6	4						
504	M9 1110 002	W500294H01	平 ネ ジ 11 64(40)×8	Screw 11 64(40)×8	4						
505	MF 05A0 339	A120B111E01	アームカバー	Arm cover	1						
506	M9 1504 002	B508963HC1	平 ネ ジ 15 64(28)×10	Screw 11 64(40)×5.5	1						
507	MS 05A1 601	A130C358F01	Fトリツケイタ	F plate	1						
508	M9 1101 004	W466810H01	フ ラ マ イ ネ ジ 11 64(40)×8	Screw 11 64(40)×8	4						
509	M9 0550 050	S913N040F05	サ ガ ネ 5	Washer 5	8						
510	MV 30A3 601	A140D419H01	L B 取 付 板	LB plate	1						
511	M9 4007 021	S903N214F08	六角穴付ボルト M4×8	Solt M4×8	4						
512	M9 0101 053	S913N210F04	バネザガネ 4	Spring washer	4						
513	MV 30A0 454	E702D610H01	ジ ャ ッ ク	Shaft	1						
514	M9 0511 065	S922N210P60	E 形 止 メ 輪	E-type stop ring	2						

PLK-2520

本体関係  
ARM BED & ITS ACCESSORIES

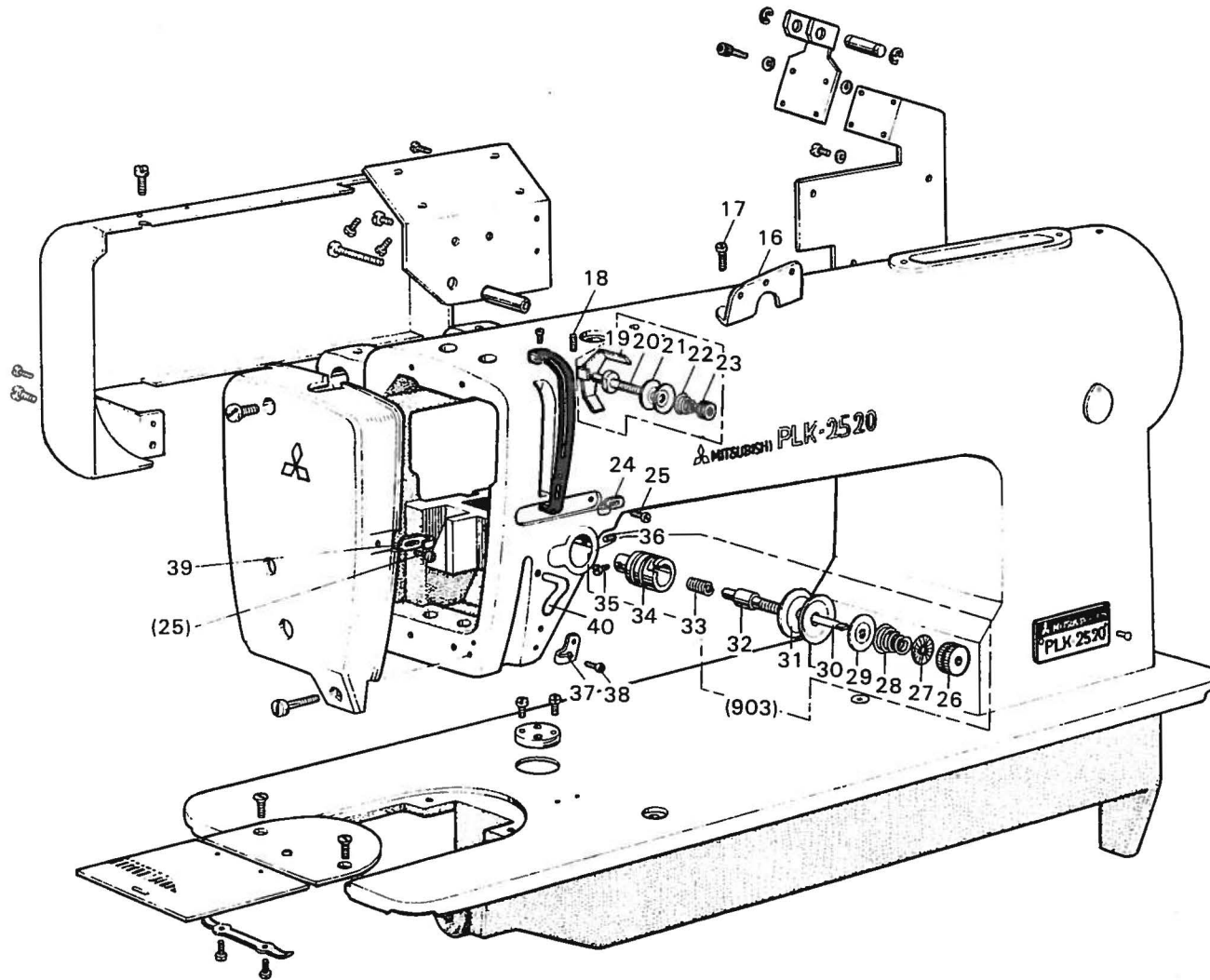

本体関

ARM BED & ITS ACCESSRIES

Fig. No.	部品コード Parts No.	資材コード Ref. No.	部 品 名	Description	使用 個数 Amt. Req.	共通部品 Common Parts							
						IDY-349-22-BZ	PV-2000-349	PLK-2520					
16	MF 36A1 180	W471432-H01	糸 案 内 (上)	Thread guide	1	●	○	○					
17	M9 1116 002	W501400-H01	平 ネ ジ 11 64(40)×8	Screw 11 64(40)×8	1	●	○	○					
18	M9 1108 001	B 503846-H01	頭ナシ止メネジ 11 64(40)×5.5	Screw 11 64(40)×5.5	1	●	○	○					
19	MF 90A0 181	W487038-H01	糸 案 内 (プリテンション)	Thread guide	1	●	○	○					
20	MF 90A0 553	W487037-H01	調 子 棒	Thread tension releasing pin	1	●	○	○					
21	MF 10A1 555	W501636-H01	調 子 皿	Thread tension discs	2	●	○	○					
22	MF 36A0 245	W462881-H01	円 錐 バ ネ	Thread tension spring	1	●	○	○					
23	M9 1101 046	W501637-H01	ツ マ ミ ナ ッ ト	Thumb nut	1	●	○	○					
902	MF 90E0 550	W487036G02	調 節 器 (組)(プリテンション)	Pre-tension complete	1	●	○	○					
24	MF 83A0 181	W483485-H01	糸 案 内 (中)	Thread guide	1	●	○	○					
25	M9 0909 003	W501901-H01	丸 平 ネ ジ 9 64(40)×6	Screw 9 64(40)×6	2	●	○	○					
26	M9 1608 046	W476469-H01	調 節 ナ ッ ト (上糸調節器)	Thumb nut	1	●	○	○					
27	MT 60A0 802	W476470-H01	回 り 止 メ (上糸調節器)	Thumb nut revolution stopper	1	●	○	○					
28	MF 43C0 245	W478173-H01	円 錐 バ ネ (上糸調節器)(厚物)	Thread tension spring	1	●	○	○					
29	MM 11A0 556	W477611-H01	調 子 皿 押 エ (上糸調節器)	Thread tension releasing disc	1	●	○	○					
30	M9 0204 060	B 509216-H01	ビ ン (上糸調節器)	Thread tension releasing pin	1	●	○	○					
31	MF 10A0 555	W444059-H01	調 子 皿 (上糸調節器)	Thread tention discs	2	●	○	○					
32	MF 10A0 553	B 419178-H01	調 子 棒 (上糸調節器)	Thread tension stud	1	●	○	○					
33	MF 12B0 187	W486372-H02	糸 取 り バ ネ (上糸調節器)(厚物)	Thread Take-up spring	1	●	○	○					
34	MF 10A0 709	W453140-H01	ブ ッ シ ュ (上糸調節器)	Thread tension regulator bushing	1	●	○	○					
35	M9 0901 002	W500741-H01	平 ネ ジ 9 64(40)×4	Screw 9 64(40)×4	1	●	○	○					
36	M9 1508 001	B 509088-H01	頭ナシ止メネジ 15 64(28)×8	Screw 15 64(28)×8	1	●	○	○					
903	MF 12E0 210	W346065G02	上 糸 調 節 器 (組)(厚物)	Thread tension regulator complete	1	●	○	○					
37	MQ 50A0 181	W464979-H01	糸 案 内 (アーム下)	Thread guide	1	●	○	○					
38	M9 0906 002	W500791-H01	平 ネ ジ 9 64(40)×4.5	Screw 9 64(40)×4.5	1	●	○	○					
39	MG 43A1 181	W487127-H01	糸 案 内 (面板)	Thread guide	1	●	○	○					
40	MF 70A1 180	W481679-H01	糸 案 内	Thread guide				○					

PLK-2520

天秤・針棒

THREAD TAKE-UP LEVER & NEEDLE BAR MECHANISM

PLK-2520

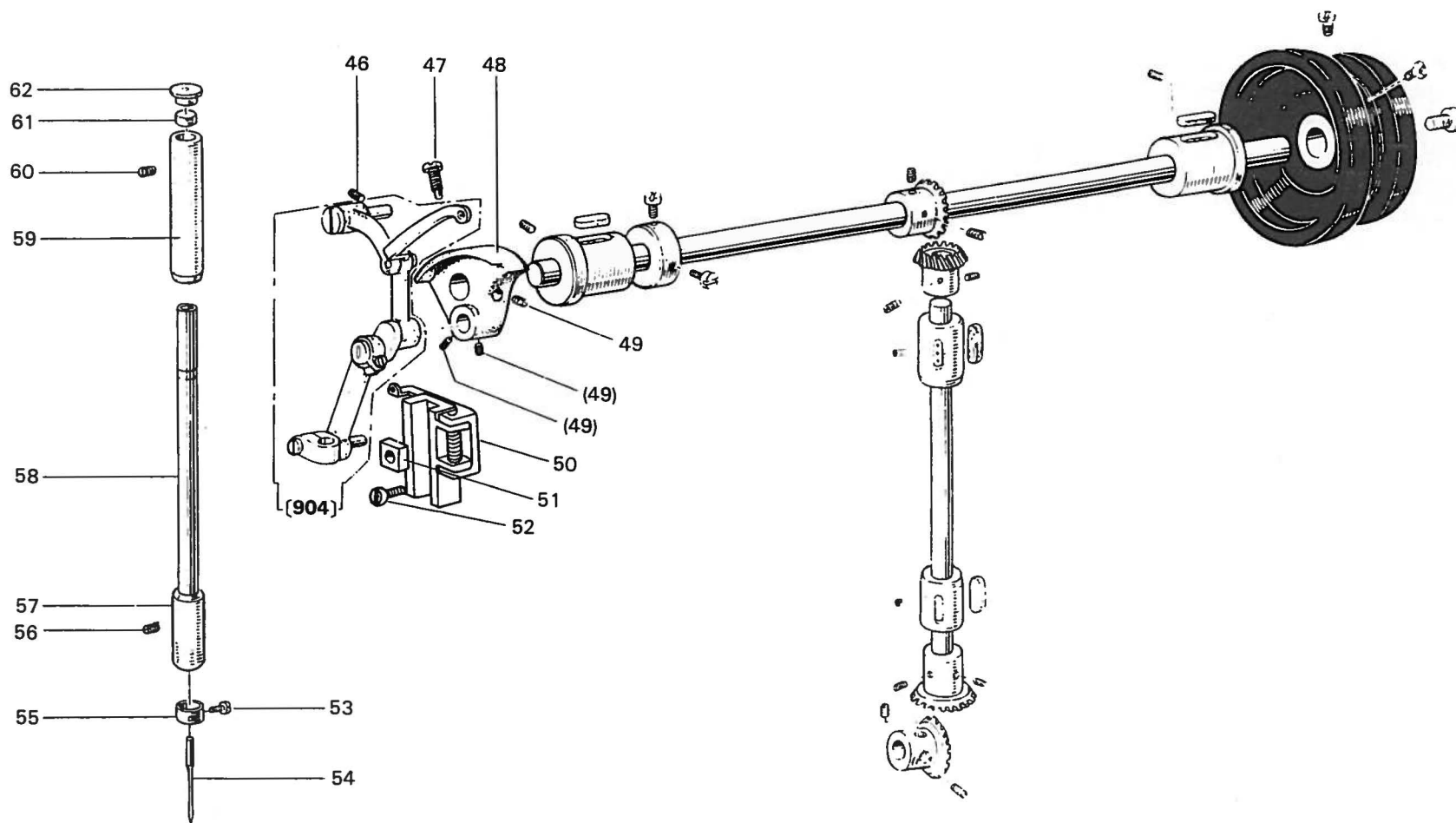

天秤・針棒関係

THREAD TAKE-UP LEVER & NEEDLE BAR MECHANISM

Fig. No.	部品コード Parts No	資材コード Ref. No.	部品名	Description	使用 個数 Amt. Req.	共通部品 Common Parts												
						DY-349-22-BZ	PV-2000-349	PLK-2520										
46	M9 1519 001	B 509114H01	頭ナシ止メネジ 15 64(28)×23.5	Screw 15 64(28)×23.5	1	○		○										
47	M9 1802 006	B 503851H01	棒先止メネジ 9 32(28)×14	Screw 9 32(28)×14	1	○		○										
48	MF 60A1 383	W450075H03	クランク	Crank	1			○		○								
<b>904</b>	<b>MS 05E0 580</b>	<b>W331012G06</b>	天秤針ク(組)	<b>Thread take-up lever complete</b>	<b>1</b>	○				○								
49	M9 1606 001	B 504016H01	頭ナシ止メネジ 1 4(40)×7	Screw 1 4(40)×7	3	○		○		○								
50	MG 44E0 662	W488439G01	針クガイド(組)	Needle bar connecting link guide	1	○		○		○								
51	MF 10A0 325	W443934H01	角駒	Square block	1	○		○		○								
52	M9 1110 002	W500294H01	平ネジ 11 64(40)×8	Screw 11 64(40)×8	2	○		○		○								
53	M9 0815 002	W484210H01	平ネジ 1 8(44)×4.5	Screw 1 8(44)×4.5	1	○		○		○								
54	MP 20B0 128	S 970005H02	針 DP×17 #23	Needle DP×17 #23	1			○		○								
55	MG 42A0 181	W487123H01	糸案内(針棒)	Thread guide for needle bar	1	○		○		○								
56	M9 1102 001	W500489H01	頭ナシ止メネジ 11 64(40)×2.7	Screw 11 64(40)×2.7	1	○		○		○								
57	MQ 50A0 664	W458121H01	針棒メタル(下)	Needle bar bushing (lower)	1	○		○		○								
58	MG 44B0 660	W488438H01	針棒	Needle bar	1	○		○		○								
59	MF 60A0 663	W461760H01	針棒メタル(上)	Needle bar bushing (upper)	1	○		○		○								
60	M9 1503 001	B 508971H01	頭ナシ止メネジ 15 64(28)×4.5	Screw 15 64(28)×4.5	1	○		○		○								
61	MF 10A2 740	W500003H01	フェルト	Felt for needle bar bushing (upper)	1	○		○		○								
62	MF 60A0 742	W502181H01	蓋	Cap for needle bar bushing (upper)	1	○		○		○								

PLK-2520

上軸・豎軸關係

ARM SHAFT & VERTICAL SHAFT MECHANISM

PLK-2520

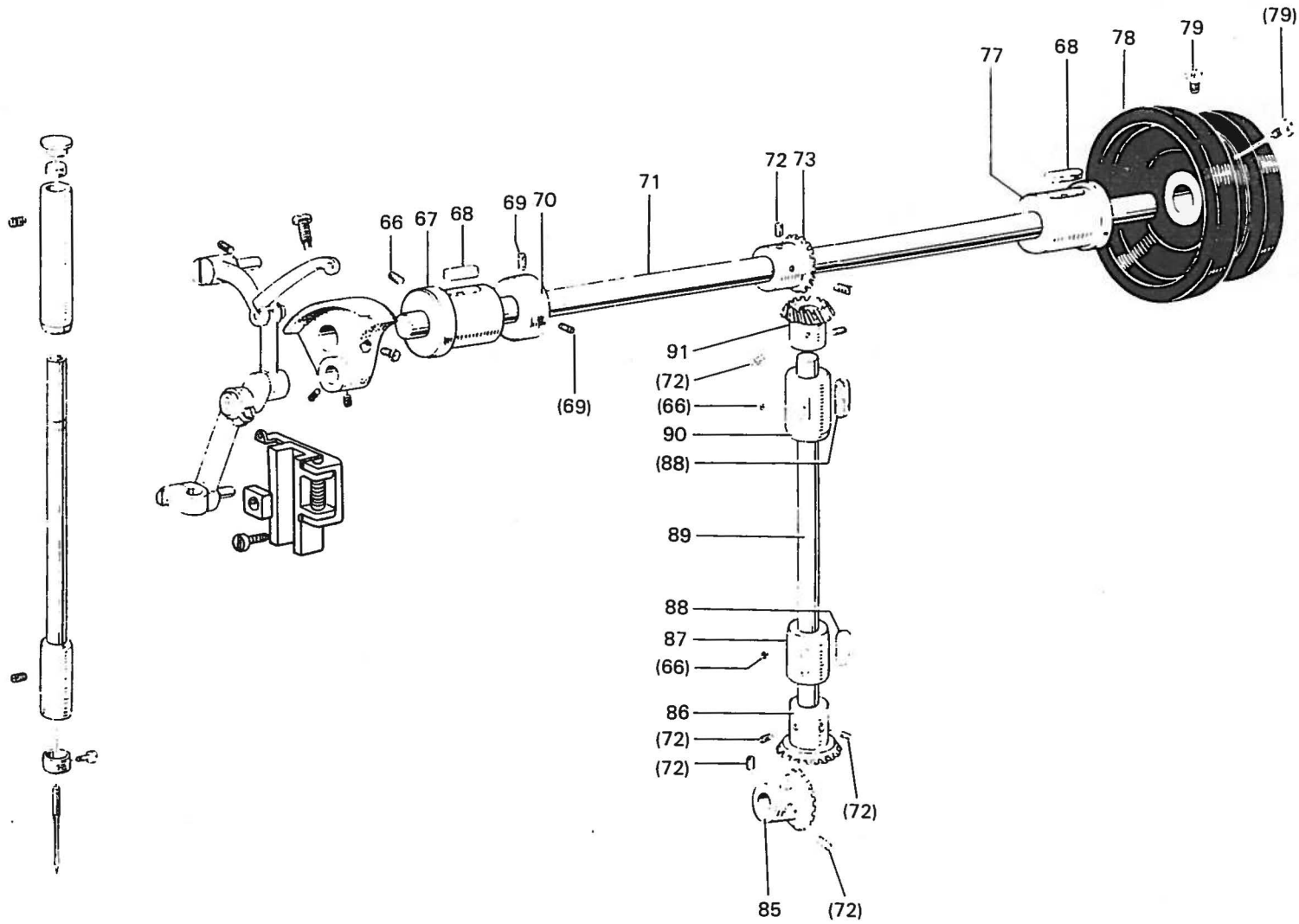



上軸・縦軸関係

ARM SHAFT & VERTICAL SHAFT MECHANISM

Fig. No.	部品コード Parts. No.	資材コード Ref. No.	部 品 名	Description	使用 個数 Amt. Req.	共通部品 Common Parts								
						IDY-349-22-BZ	PV-2000-349	PLK-2520						
66	M9 1519 001	B 509088H01	頭ナシ止メネジ 15 64(28)×7	Screw 15 64(28)×7	3									
67	MF 60A0 232	W464011H01	上軸メタル (左)	Arm shaft bushing (left)	1									
68	MF 60A2 740	W501524H01	フェルト	Felt for arm shaft bushing	2									
69	M9 1602 001	W500036H01	頭ナシ止メネジ 1 4(40)×4	Screw 1 4(40)×4	2									
70	MF 70A0 352	W476422H01	カラ	Collar for arm shaft	1									
71	MG 41B0 230	W341673H01	上軸	Arm shaft	1									
72	M9 1606 001	P 911000X01	頭ナシ止メネジ 1 4(40)×7	Screw 1 4(40)×7	8									
73	MF 40A0 331	P 611003X02	傘歯車 (上軸)	Bevel gear for arm shaft	1									
77	MF 60A0 233	W451575H01	上軸メタル (右)	Arm shaft bushing (right)	1									
78	MF 10A0 682	W453500H01	ハズミ車	Balance wheel	1									
79	M9 1502 002	W500509H01	平ネジ 15 64(28)×12	Screw 15 64(28)×12	2									
85	MF 40A0 332	P 611002X02	傘歯車 (下軸)	Bevel gear for hook shaft	1									
86	MF 40A0 334	P 611001X02	傘歯車 (縦軸下)	Bevel gear for vertical shaft (lower)	1									
87	MF 67B0 522	W462734H01	縦軸メタル (下)	Vertical shaft bushing (lower)	1									
88	MF 60A0 740	W500042H01	フェルト	Felt for vertical shaft bushing	2									
89	MG 41B0 520	W481658H01	縦軸	Vertical shaft	1									
90	MG 37B0 521	W462791H01	縦軸メタル (上)	Vertical shaft bushing (upper)	1									
91	MF 40A0 333	P 611000X02	傘歯車 (縦軸上)	Bevel gear for vertical shaft (upper)	1									

PLK-2520

押工関係  
PRESSER FOOT MECHANISM

PLK-2520

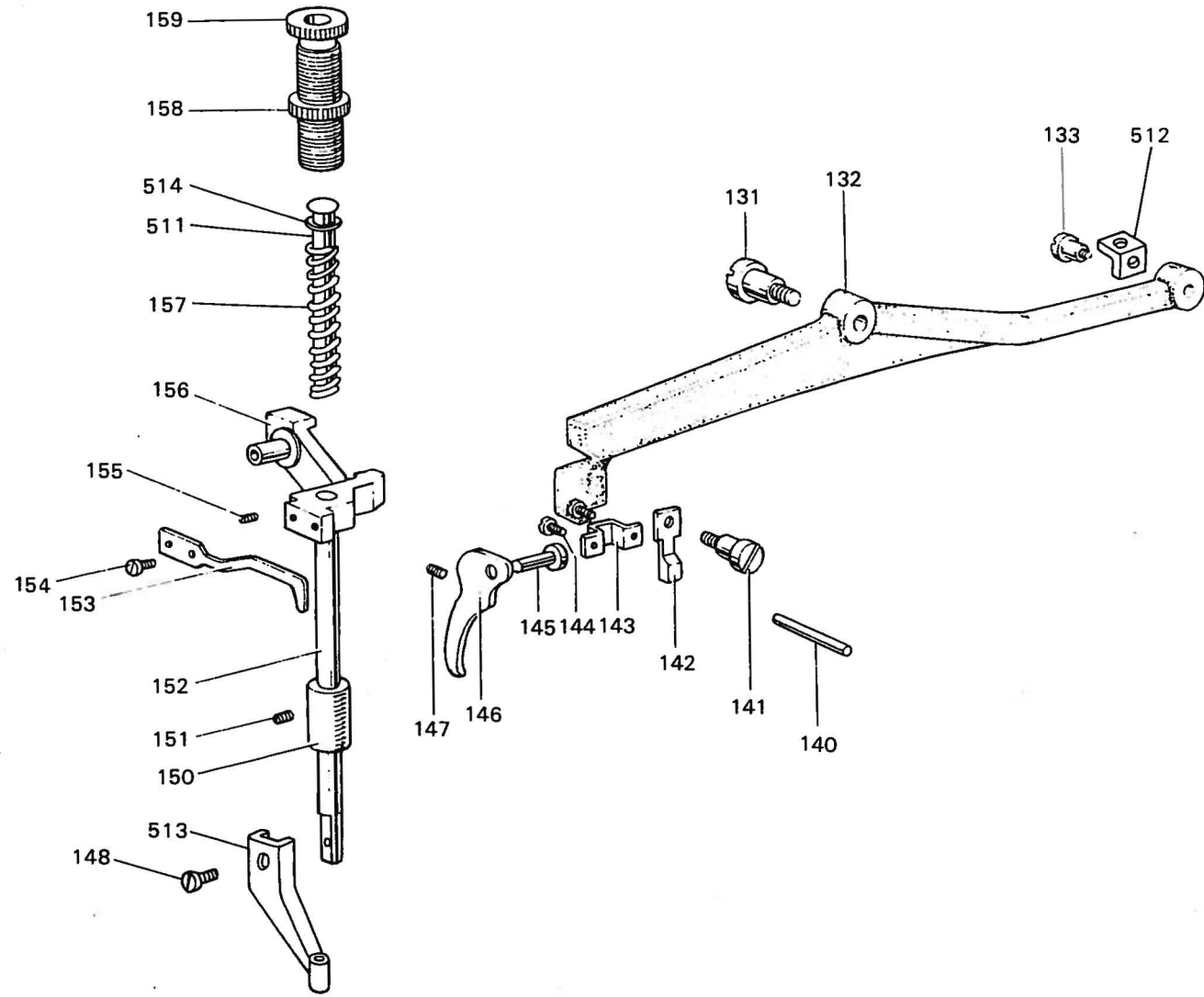

押工関係  
PRESSER FOOT MECHANISM

Fig. No.	部品コード Parts. No.	資材コード Ref. No.	部 品 名	Description	使用 個数 Amt. Req.	共通部品 Common Parts						
						Y-349-22BZ	PLV-2000-349	PLK-2520				
131	M9 2001 016	B 503843H01	段付丸平ネジ 5 16(24)×30	Screw 5 16(24)×30	1							
132	MG 30AO 725	W344931H01	膝上ゲレバー (上)	Lifting lever (upper)	1							
133	M9 1505 016	B 509176H01	段付丸平ネジ 15 64(28)×10	Screw 15 64(28)×10	1							
140	M9 0414 060	W502957F-07	糸ユルメピン φ4×39	Thread releasing pin	1							
141	M9 1223 015	W487004H01	段付平ネジ 3 16(28)×6.2	Screw 3 16(28)×6.2	1							
142	MG 30B1 222	W483465H01	糸ユルメ (糸ユルメカム)	Thread releasing cam	1							
143	MG 30AO 154	W483466H01	案内金	Guide plate	1							
144	M9 1109 002	W500511H01	平ネジ 11 64(40)×7	Screw 11 64(40)×7	2							
148	M9 0922 002	W464016H01	平ネジ 9 64(40)×8	Screw 9 64(40)×8	1							
150	MG 30BO 267	W462887F-01	押エ棒メタル	Presser bar bushing	1							
151	M9 1102 001	W500489F-01	頭ナシ止メネジ 11 64(40)×2.7	Screw 11 64(40)×2.7	2							
152	MF 10AO 267	W502079F-01	押エ棒	Presser bar	1							
153	MN 30AO 216	W502468F-01	案内	Thread guide	1							
154	M9 1107 002	W500092H01	平ネジ 11 64(40)×5.5	Screw 11 64(40)×5.5	1							
155	M9 1508 001	B 509088H01	頭ナシ止メネジ 15 64(28)×8	Screw 15 64(28)×8	1							
156	MF 41BO 265	W481630G01	押エ棒ダキ	Presser bar holder	1							
157	MV 30AO 259	W489017G01	押エバネ	Presser bar spring	1							
158	M9 3201 045	W471438F-01	特殊ナット 1 2(28)	Special nut 1 2(28)	1							
159	M9 3209 035	W481436F-01	押エ調節ネジ 1 2(28)×43	Presser regulating thumb screw 1 2(28)×43	1							
511	MF 20AO 703	W475491F-01	案内棒(押エバネ)	Presser barguide	1							
512	MV 30AO 571	BE702D661H01	継手	Adapter	1							
513	MV 30AO 256	A130C201H01	オサエ (針穴φ3)	Presser foot (φ3)	1							
514	M9 0551 050	S913N010P06	小形丸座金	Washer	1							

PLK-2520

## 上部送り関係

## UPPER FEED MECHANISM

PLK-2520

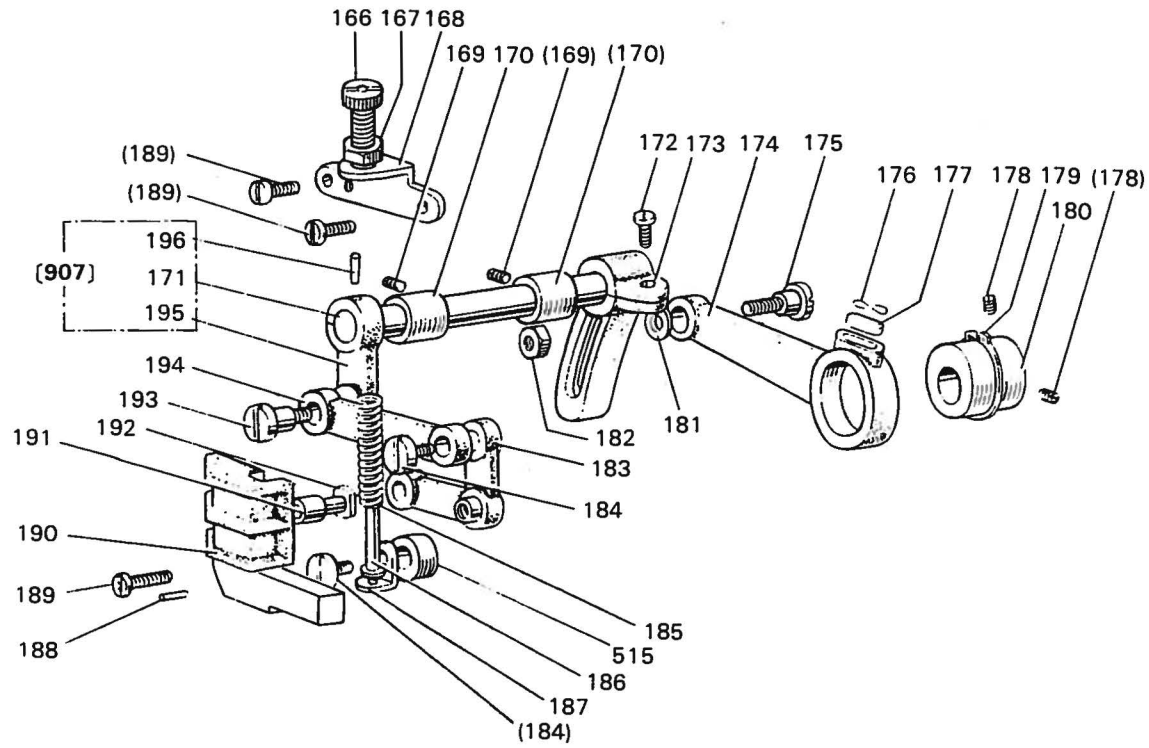

上部送り関係

UPPER FEED MECHANISM

Fig. No.	部品コード Parts. No.	資材コード Ref. No.	部 品 名	Description	使用 個数 Amt. Req.	共通部品 Common Parts					
						IDY 349-22-BZ)	(PV 2000 349)	PLK-2520			
166	M9 1801 035	W502411H01	調 節 ネ ジ 9 32(28)×35	Feed regulating screw 9 32(28)×35	1						
167	M9 1801 045	W500009H01	ナ ッ ト 9 32(28)	Nut 9 32(28)	1						
168	MG 30B1 261	W480473H01	押 エ 調 節 台	Presser regulating bracket	1						
169	M9 1108 001	B 503846H01	頭ナシ止メネジ 11 64(40)×5.5	Screw 11 64(40)×5.5	2						
170	MG 30A0 833	W483458H02	送り軸メタル (上部上下)	Feed lifting rock shaft bushing	2						
171	MG 30A0 460	W483458H02	上 部 上 下 軸	Feed lifting rock shaft	1						
172	M9 1603 003	W501009H01	丸 平 ネ ジ 1 4(24)×16	Screw 1 4(24)×16	1						
173	MG 30A0 463	W483457H01	上部下上送り腕 (右)	Feed lifting rock shaft crank (right)	1						
174	MG 20B0 384	W480485H01	クランクロッド (連結桿)	Feed connecting crank rod	1						
175	M9 1551 015	W480471H02	段 付 平 ネ ジ M6 PO 75×24	Screw M6 PO 75×24	1						
176	MF 60A0 700	W500836H01	バ ネ	Spring for felt stopper	1						
177	MF 60A1 740	W500738H01	フ ェ ル ト	Felt for feed connecting crank rod	1						
178	M9 1606 001	B 504016H01	頭ナシ止メネジ 1 4(40)×7	Screw 1 4(40)×7	2						
179	M9 0325 065	S 591411H05	C 形 止 メ 輪 (偏心輪)	C-type stop ring	1						
180	MG 30A0 760	W483455H01	偏 心 輪	Feed lifting eccentric	1						
181	M9 0607 050	S 562131H04	ミ ガ キ 座 金 6	Washer 6	1						
182	M9 1572 045	S 542112H01	U ナ ッ ト M6×0.75	U-nut 6×0.75	1						
183	MG 10B0 763	W461042H01	ベルクワンク	Bell crank	1						
184	M9 1210 002	W501247H01	平 ネ ジ 3 16(28)×10	Screw 3 16(28)×10	2						
185	MG 41B1 572	W502462H01	押 エ バ ネ (ツル巻バネ)	Spring	1						
186	MG 30B0 732	W464020G01	ピン案内金 (組)	Spring guide bar complete	1						
187	MG 30B0 226	W461057H01	押 エ 板 支 エ (受金)	Adapter	1						
188	M9 0301 064	S 584412H03	スプリングピン	Spring Pin	2						
189	M9 1110 002	W500294H01	平 ネ ジ 11 64(40)×8	Screw 11 64(40)×8	3						
190	MS 05A0 765	A140D824H01	ベルクワンクガイド	Bell crank guide bracket complete	1						
191	MG 10B0 411	W501534H01	コ ロ	Roller	1						
192	M9 0507 063	W502457H01	コ ロ 軸 (支エ軸)	Bell crank guide pin	1						
193	M9 1681 015	W480472H01	段 付 平 ネ ジ 1 4(40)×12	Screw 1 4(40)×12	1						
194	MG 10B0 910	W457552H01	リ ン ク (連接桿)	Feed lifting rock shaft link	1						
195	MG 30A0 462	W488479H01	上部上下送り腕 (左)	Upper feed lifting rock shaft crank	1						
196	M9 1506 022	W488368H01	テ ー ハ ヒ ン	Taper pin	1						
907	MG 30E0 460	W488478G01	上 部 上 下 軸 (組)	Feed lifting rock shaft complete	1						
515	MV 30A0 352	BE702D607H01	カ ラ	Collar	1						

PLK-2520

下軸・カマ関係

HOOK SHAFT & ROTATING HOOK MECHANISM

PLK-2520

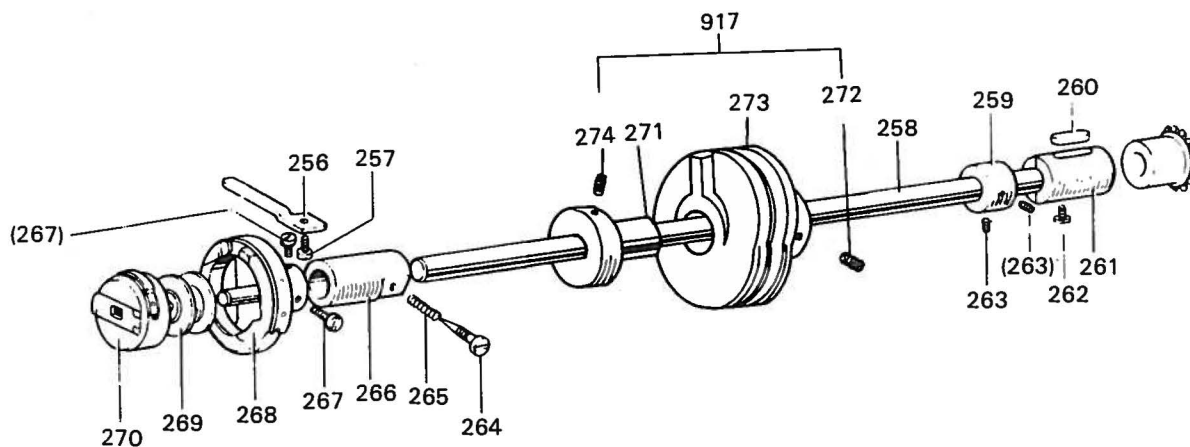

下軸・カマ関係

HOOK SHAFT & ROTATING HOOK MECHANISM

Fig. No.	部品コード Parts. No.	資材コード Ref. No.	部 品 名	Description	使用 個数 Amt. Req.	共通部品 Common Parts			
						IDY-349-22-RZ	PV-2000-349	PLK-2520	
256	MF 20AO 229	W468837H01	内ガマ止メ	Hook positioner	1				
257	M9 1118 002	B 509061H01	平ネジ 11 64(40)×10	Screw 11 64(40)×10	1				
258	MG 44BO 450	W488437G01	下軸	Hook shaft	1				
259	MF 10AO 352	B 422844H01	カラ	Collar for hook shaft	1				
260	MF 60AO 740	W500042H01	フェルト	Felt	1				
261	MG 37BO 452	W462738H01	下軸メタル (右)	Hook shaft bushing (right)	1				
262	M9 1117 002	B 503844H01	丸平ネジ 11 64(40)×13	Screw 11 64(40)×13	1				
263	M9 1503 001	B 508971H01	頭ナシ止メネジ 15 64(28)×4.5	Screw 15 64(28)×4.5	2				
264	M9 0811 006	W48700801H	棒先平ネジ M3×0.35×9.5	Screw M3×0.35×9.5	1				
265	MG 30AO 700	W487009H01	バネ	Spring	1				
266	MG 30AO 451	W487008H01	下軸メタル (左)(組)	Hook shaft bushing (left)	1				
267	M9 1103 002	B 509062H01	平ネジ 11 64(40)×5	Screw 11 64(40)×5	2				
268	MG 44BO 120	P 975040X02	カマ	Hook complete	1				
269	MG 44BO 123	W470215H02	ホビン	Bobbin	1				
270	MG 44EO 125	P 976027X01	ホビンケース (組)	Bobbin case complete	1				
270	MS 05EO 125	A 190D073P01	// (//)新	Bobbin case complete	1				
271	MF 90AO 750	A 140D003H01	ブッシュ	Hook shaft collar	1				
272	M9 1602 020	W462663H01	六角穴付止メネジ 1 4(40)×10	Screw 1 4(40)×10	1				
273	MF 90AO 350	A 130C001H01	糸切りカム	Thread trimmer cam	2				
274	M9 1601 020	W462662H01	六角穴付止メネジ 1 4(40)×6	Screw 1 4(40)×6	4				
917	MF 90EO 350	A140D002G01	糸切りカム(組)	Thread trimmer cam complete					

PLK-2520

メス(糸切り)関係  
KNIF (ACTUATING) MECHANISM

PLK-2520

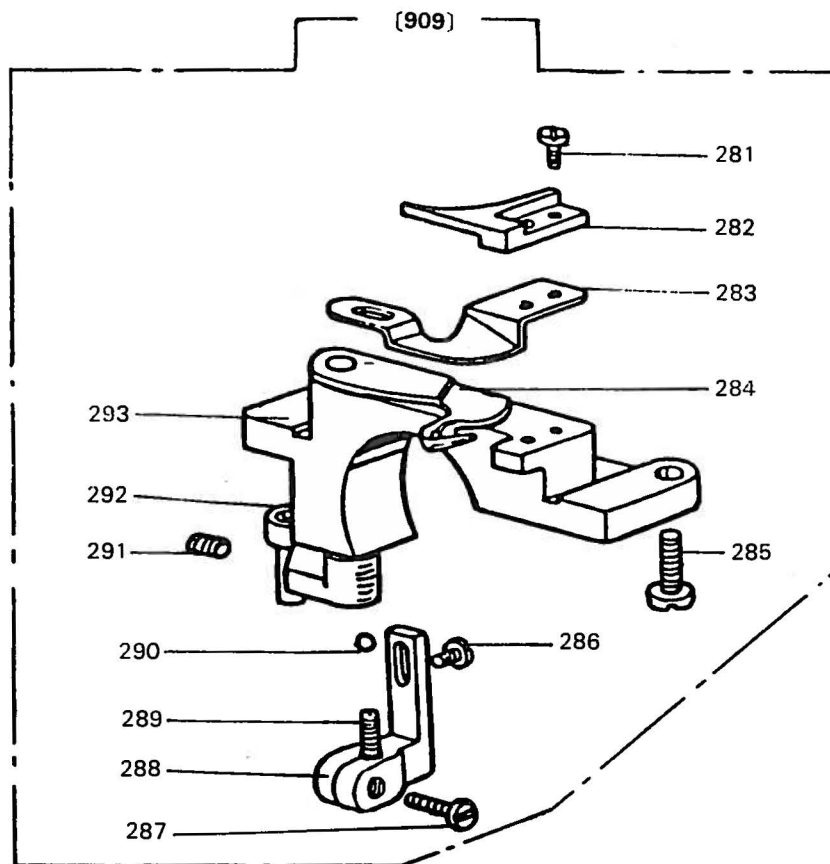



# メス(糸切り)関係 KNIFE ACTUATING MECHANISM

Fig No.	部品コード Parts No.	資材コード Ref. No.	部 品 名	Description	使用 個数 Amt. Req.	共通部品 Common parts		
						(DY 349-22 BZ)	(PV 2000-349)	PLK-2520
909	MF 90E1 199	W231513G03	メ ス 台 (組)	Knif base complete	1			
281	M9 0803 003	W502920H01	丸 平 ネ ジ 1 8(44)×6	Screw 1 8(44)×6	2			
282	MF 90A0 838	W344956H02	固 定 メ ス	Fixed knife	1			
283	MF 90A0 180	W344976H02	糸 案 内	Thread guide for knife	1			
284	MF 90B2 838	W344947G02	移 動 メ ス (組)	Movable knife	1			
284	MG 44B0 838	A 130C429G01	// (//) 新	Movable knife	1			
285	M9 1204 003	B 503840H01	丸 平 ネ ジ 3 16(28)×12	Screw 3 16(28)×12	2			
286	M9 0910 003	B 509270H01	丸 平 ネ ジ 9 64(40)×7	Screw 9 64(40)×7	2			
287	M9 1112 002	W501889H01	平 ネ ジ 11 64(40)×18	Screw 11 64(40)×18	1			
288	MF 90A0 839	W487156H01	移 動 メ ス 調 節 台	Adjusting bracket	1			
289	M9 1110 030	W488922H01	移 動 メ ス 調 節 ネ ジ	Screw	1			
290	M9 8001 070	W469183H01	鋼 球 (3 32)	Steel ball	1			
291	M9 1050 020	W488510H01	六角穴付止メネジ M4×5	Screw M4×5	1			
292	MF 90A2 228	W487095G02	移 動 メ ス 腕	Movable knife crank	1			
293	MF 90A2 839	W344954H02	メ ス 台	Knife bracket	1			

PLK-2520

カム軸取付台関係  
CAM SHAFT BRACKET

PLK-2520

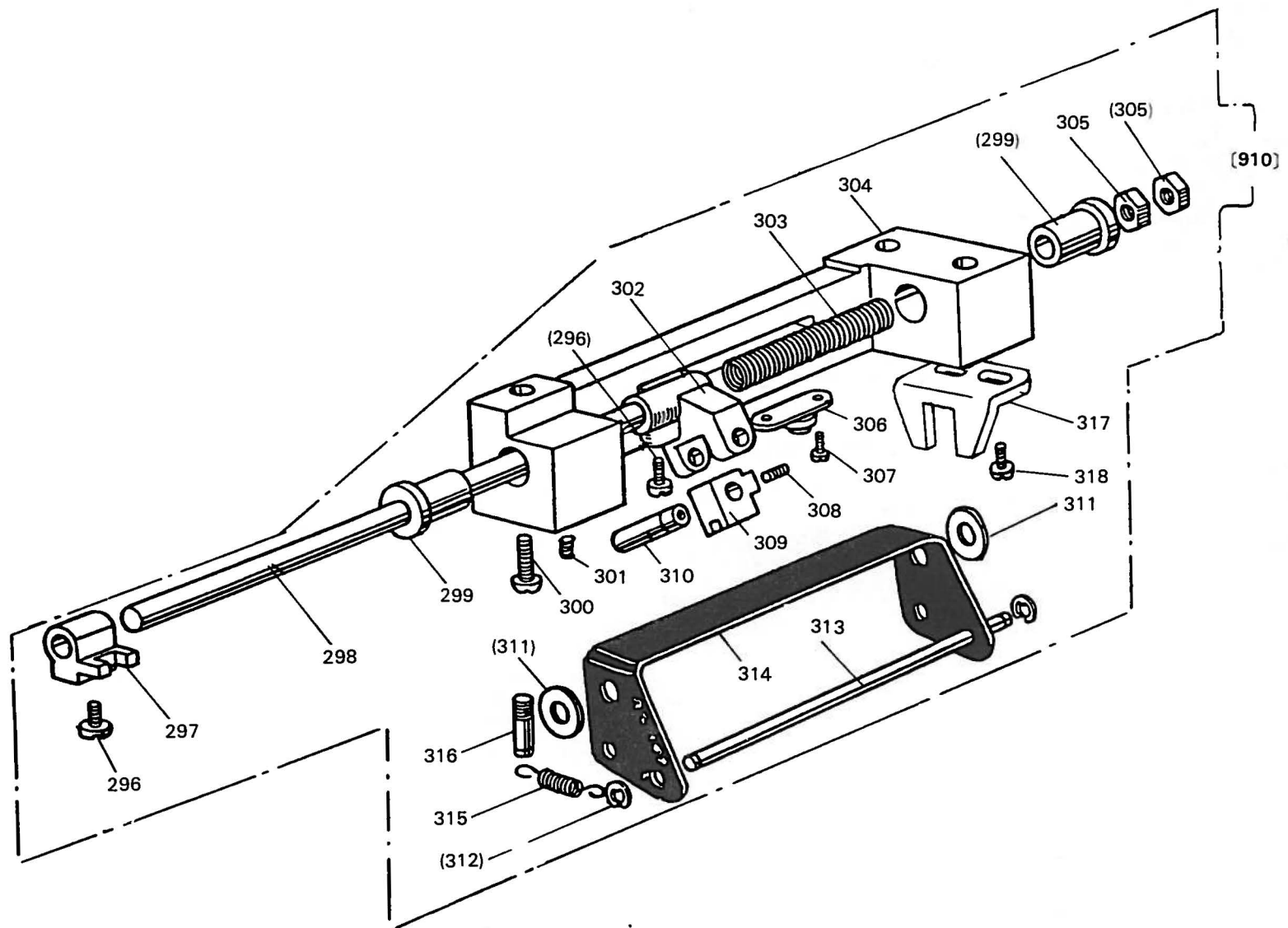

# カム軸取付台関係 CAM SHAFT BRACKET

Fig No.	部品コード Parts No.	資材コード Ref. No.	部 品 名	Description	使用 個数 Amt. Req.	共通部品 Common Parts			
						(DY-349-22-BZ)	(PV-2000-349)	PLK-2520	
910	MG 44E1 348	W344958G05	カム軸取付台 (組)	Cam shaft bracket complete	1				
296	M9 1516 002	W502945H02	平ネジ 15 64(28)×8.5	Screw 15 64(28)×8.5	2				
297	MF 90A1 744	W487051H02	メス駆動ニ又	Knife driving fork	1				
298	MF 90A0 348	W487046H01	カム軸	Cam shaft	1				
299	MF 90A0 833	W487039H02	カム軸メタル	Bushing for cam shaft	2				
300	M9 1509 001	B 509074H01	平ネジ 15 64(28)×30	Screw 15 64(28)×30	3				
301	M9 1109 001	W500985H01	頭ナシ止メネジ 11 64(40)×6.6	Screw 11 64(40)×6.6	2				
302	MG 44E0 351	W488446G01	カム追従腕	Cam follower crank	1				
303	MF 90A1 572	W487050H02	ツル巻バネ	Spring	1				
304	MG 44B0 348	W488443G01	カム軸取付台	Cam shaft bracket	1				
305	M9 2001 045	W501512H01	ナット 5 16(24)	Nut 5 16(24)	2				
306	MG 44E0 410	W488447G01	コロ (組)	Roller complete	1				
307	M9 1110 002	W500294H01	平ネジ 11 64(40)×8.0	Screw 11 64(40)×8.0	2				
308	M9 1351 020	M5×5	六角穴付止メネジ M5×5	Screw M5×5	1				
309	MF 90A0 665	W487049H02	コロ軸ダキ	Roller shaft bracket	1				
310	MF 90E0 410	W487096G01	コロ軸 (組)	Roller shaft complete	1				
311	M9 0814 050	W487040H01	座金	Washer	2				
312	M9 0504 065	S 592411H04	E形止メ輪 4	E-type retaining ring	2				
313	M9 0510 060	W487042H01	糸切り作動ピン	Actuating pin	1				
314	MG 44E0 430	W488444G01	糸切り作動腕 (組)	Actuating crank	1				
315	MF 90A2 572	W487173H01	ツル巻バネ	Spring	1				
316	M9 1101 030	W502032H01	バネ掛ケピン	Pin for spring	1				
317	MF 90A0 477	W488429H01	ストップ板	Stopper	1				
318	M9 1118 902	B 509061H01	平ネジ 11 64(40)×10	Screw	2				

PLK-2520

ピッカー及び糸切り作動関係  
PICKER AND UNDER BED TRIMMER ACTATOR

PLK-2520

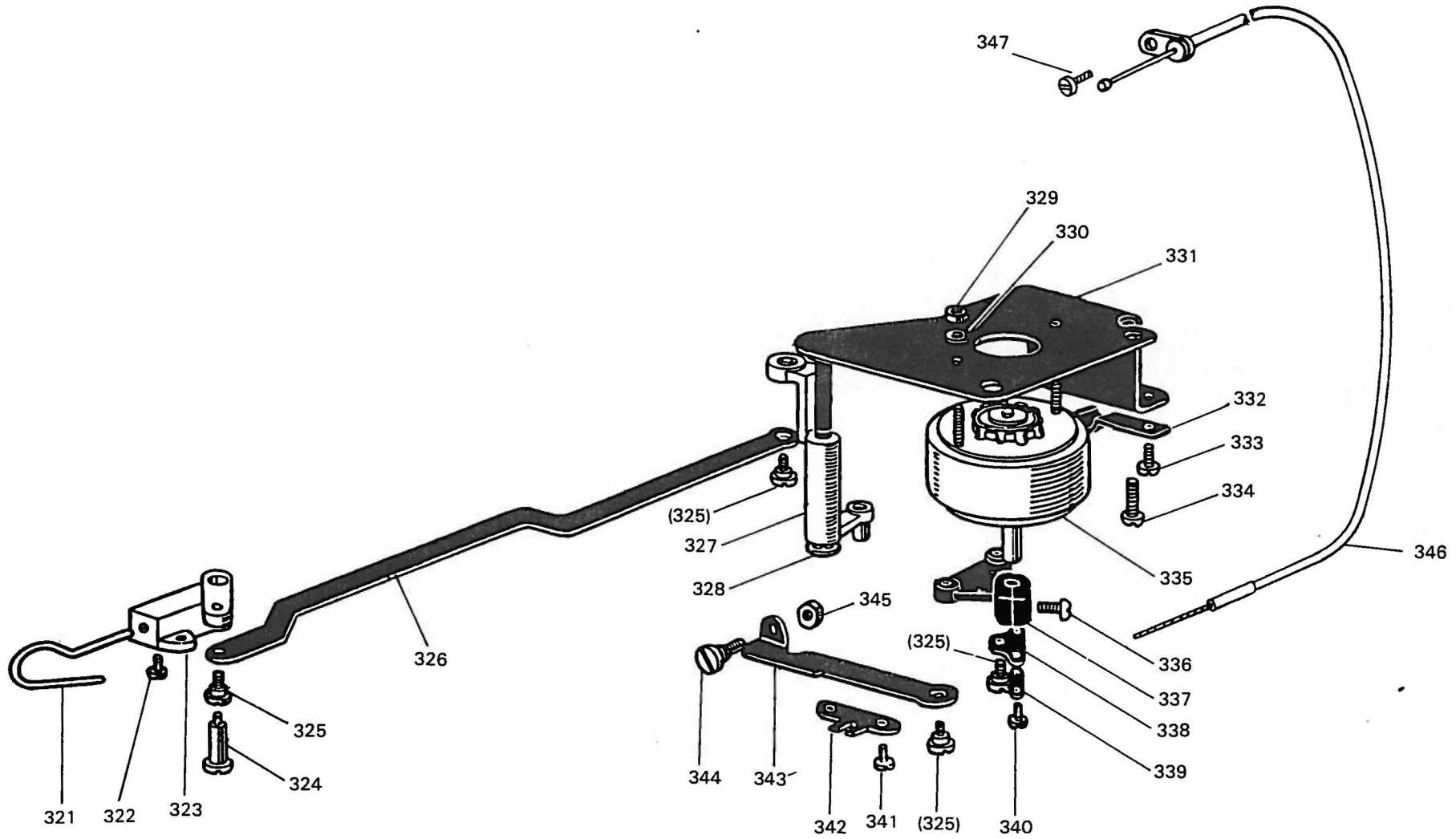

ピッカー及び糸切り作動関係

PICKER AND UNDERBED TRIMMER ACTUATER

Fig. No.	部品コード Parts. No.	資材コード Ref. No.	部 品 名	使用 個数 Amt. Req.	共通部品 Common Parts															
					IDY 349 22 BZ	IPV 2000 349	PLK 2520													
321	MF 90A0 182	W487057H01	ヒ ッ カ ー	Picker	1															
322	M9 0908 003	W502003H01	丸 平 ネ ジ 9 64(40)×5	Screw 9 64(40)×5	2															
323	MF 90A0 603	W487056H01	ヒ ッ カ ー 取 付 台	Picker bracket	1															
324	M9 1220 015	W487058H01	段 付 平 ネ ジ	Screw	1															
325	M9 1127 015	W487061H01	段 付 平 ネ ジ	Screw	4															
326	MG 44B0 427	W488449H01	ヒ ッ カ ー 作 動 リ ン グ	Picker actuating link	1															
327	MF 90A0 392	W487094G01	ヒ ッ カ ー 駆 動 腕	Picker driving crank	1															
328	M9 0505 065	S 592411H01	E 形 止 メ 輪 5	E-type stop ring 5	1															
329	M9 1002 045	M4	ナ ッ ト M4	Nut M4	2															
330	M9 0422 053	M4	ワ シ ー	Washer	2															
331	MF 90A0 601	W487064G01	ソ レ ノ イ ド 取 付 板	Solenoid braket	1															
332	MF 90A0 780	W487067H01	ホ ル ダ	Holder	1															
333	M9 1109 002	W500511H01	平 ネ ジ 11 64(40)×7	Screw 11 64(40)×7	2															
334	M9 1505 002	W500183H01	平 ネ ジ 15 64(28)×13.5	Screw 15 64(28)×13.5	2															
335	M9 1010 098	W487068G02	ロ ー タ リ ソ レ ノ イ ド	Rotary solenoid	1															
336	M9 1112 002	W501889H01	平 ネ ジ 11 64(40)×12	Screw 11 64(40)×12	1															
337	MF 90A0 430	W487069H01	作 動 腕	Crank	1															
338	MF 90A0 361	W487072H01	掛 ケ 金	Bracket	1															
339	MF 36A0 750	W502917H01	ブ ッ シ ュ	Holder	1															
340	M9 0802 002	W501083H01	平 ネ ジ 1 8(44)×7	Screw 1 8(44)×7	2															
341	M9 0922 002	W464016H01	平 ネ ジ 9 64(40)×8	Screw 9 64(40)×8	2															
342	MF 90A0 391	W487044H01	ヒ ッ カ ー 駆 動 板	Picker drive plate	1															
343	MF 90A0 910	W487043H01	リ ン ク	Link	1															
344	M9 1684 015	W487045H01	段 付 平 ネ ジ	Screw	1															
345	M9 1620 045	W482843H01	ナ ッ ト 1 4(40)	Nut 1 4(40)	1															
346	MF 90A0 746	W487070G01	フ レ キ シ ブ ル ワ イ ヤ	Flexible wire	1															
347	M9 1110 002	W500294H01	平 ネ ジ 11 64(40)×8	Screw 11 64(40)×8	1															

PLK-2520

檢 出 器  
SYNCHRONIZER MECHANISM

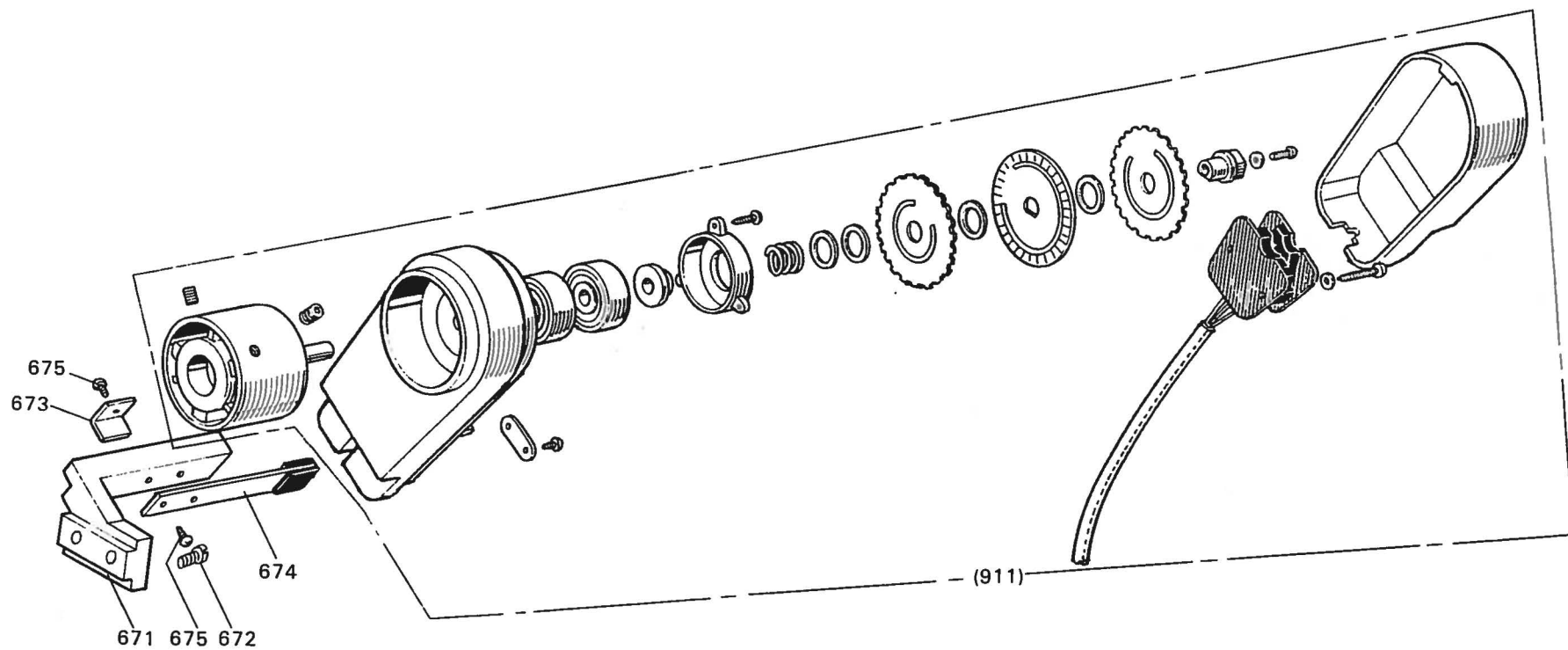

検 出 器  
SYNCHRONIZER MECHANISM

Fig. No.	部 品 コード Parts. No.	資 材 コード Ref. No.	部 品 名	Description	使用 個数 Amt. Req.	
911	MS 02E0 406	BKO-E3016H23	検 出 器 (組)	Detector complete	1	LA-K-23
671	MS 03A0 780	A 130C196H01	ホ ル ダ ー	Holder	1	
672	M9 1510 002	W500676H01	平 ネ ジ 15 64(28)×12	Screw 15 64(28)×12	2	
673	MF 40A2 780	W472745H01	コードホルダー	Cord holder	1	
674	MS 03A0 802	A140D412G01	回 リ 止 メ (組)	Stopper	1	
675	M9 1102 004	W467880H01	フ ラ マイ ネ ジ 11 64(40)×10	Screw 11 64(40)×10	3	

PCK-2520

給油關係

OIL LUBRICATION MECHANISM

PLK-2520

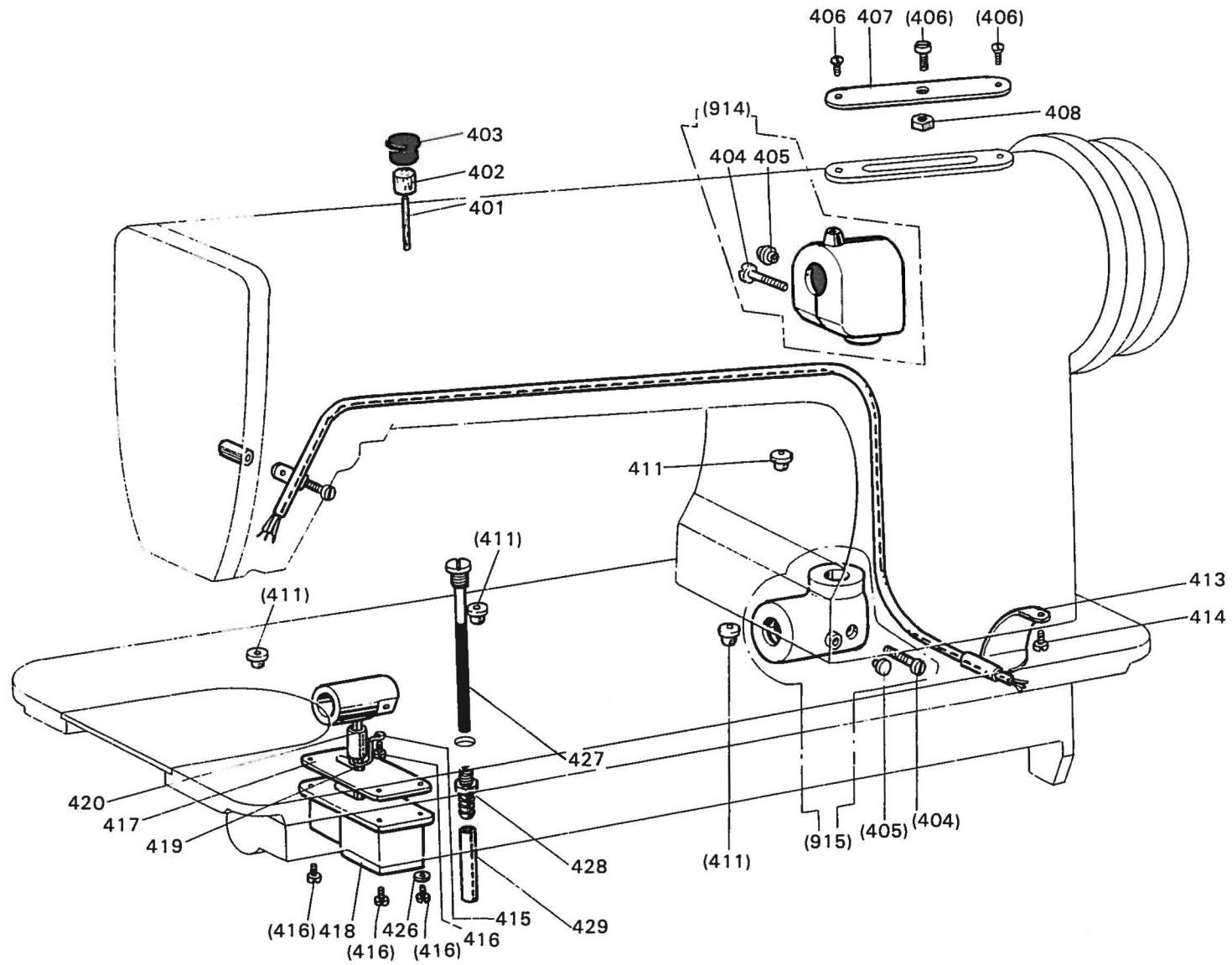



給油関係  
OIL LUBRICATION MECHANISM

Fig. No.	部品コード Parts No.	資材コード Ref. No.	部 品 名	Description	使用 個数 Amt. Req.	共通部品 Common Parts														
						IDY-349-22-BZ	PLV-2000-349	PLK-2520												
401	MF 10E2 148	W464023H01	油 紐 φ2.5×35	Oil braid φ2.5×35	1															
402	MF 60A5 740	W500906H01	フェルト	Felt for oiler	1															
403	MG 41B0 742	W471448H01	油 蓋	Cap for oiler	1															
404	M9 0501 037	S 512131H41	ナベネジ M5×12	Screw M5×12	2															
405	M9 0570 080	W502078H01	ゴム栓	Rubber plug	2															
914	MF 60E1 711	W482329G02	歯車箱上(組)	Arm shaft bevel gear box complete	1															
406	M9 1109 002	W500511H01	平ネジ 11 64(40)×7	Screw 11 64(40)×7	3															
407	MF 60A0 134	W445619H01	油 蓋 (右)(油タンク)	Oil reservoir cover (right)	1															
408	M9 1104 045	W500079H01	ナット 11/64(40)	Nut 11 64(40)	1															
411	MN 10A4 742	W462905H01	蓋 (オイルカップ)	Cap for oiler	3															
413	MF 65B0 690	W501200H01	管押エ	Oil pipe holder	1															
414	M9 0920 002	W501523H01	平ネジ 9 64(40)×6.5	Screw 9 64(40)×6.5	1															
915	MG 41E0 712	W481406G01	歯車箱下(組)	Hook shaft bevel gear box complete	1															
415	MG 43A0 689	W487120H02	センサイクバネ (パイプホルダー)	Pipe holder	1															
416	M9 1101 004	W466810H01	プライマネジ 11 64(40)×8	Screw 11 64(40)×8	5															
417	MG 42A1 691	W483469H02	ガスケット	Gasket for oil reservoir	1															
418	MS 05A0 139	A141D022G01	オイルタンク	Oil reservoir	1															
419	MN 10A5 740	W462954H01	フェルト	Felt	1															
420	MG 42A1 731	W462995H03	ビニールパイプ 6×8-15	Oil pipe 6×8-15	1															
421	MG 42B0 400	W464027H02	毛糸	Wool yarn	1															
422	M9 1104 003	B 509264H01	丸平ネジ 11 64(40)×12	Screw 11 64(40)×12	1															
423	MF 10A0 689	W444230H01	パイプホルダー	Pipe holder	1															
424	M9 1102 045	W501097H01	ナット 11 64(40)	Nut 11 64(40)	1															
425	MF 70A0 731	W482323H01	ビニールパイプ φ3×φ4.2×580	Oil pipe φ3×φ4.2×580	1															
426	M9 0406 050	W470913H01	座 金	Washer	4															
427	MS 05A0 250	A141D017G01	オイルゲージ	Oil gauge	1															
428	M9 1606 031	A141D020G01	トクシュボルト 1 4(40)	Bolt 1 4(40)	1															
429	MS 05A0 731	A141D021H01	ビニールパイプ φ5×φ7×35	Oil pipe 5×7×35	1															

PLK-2520

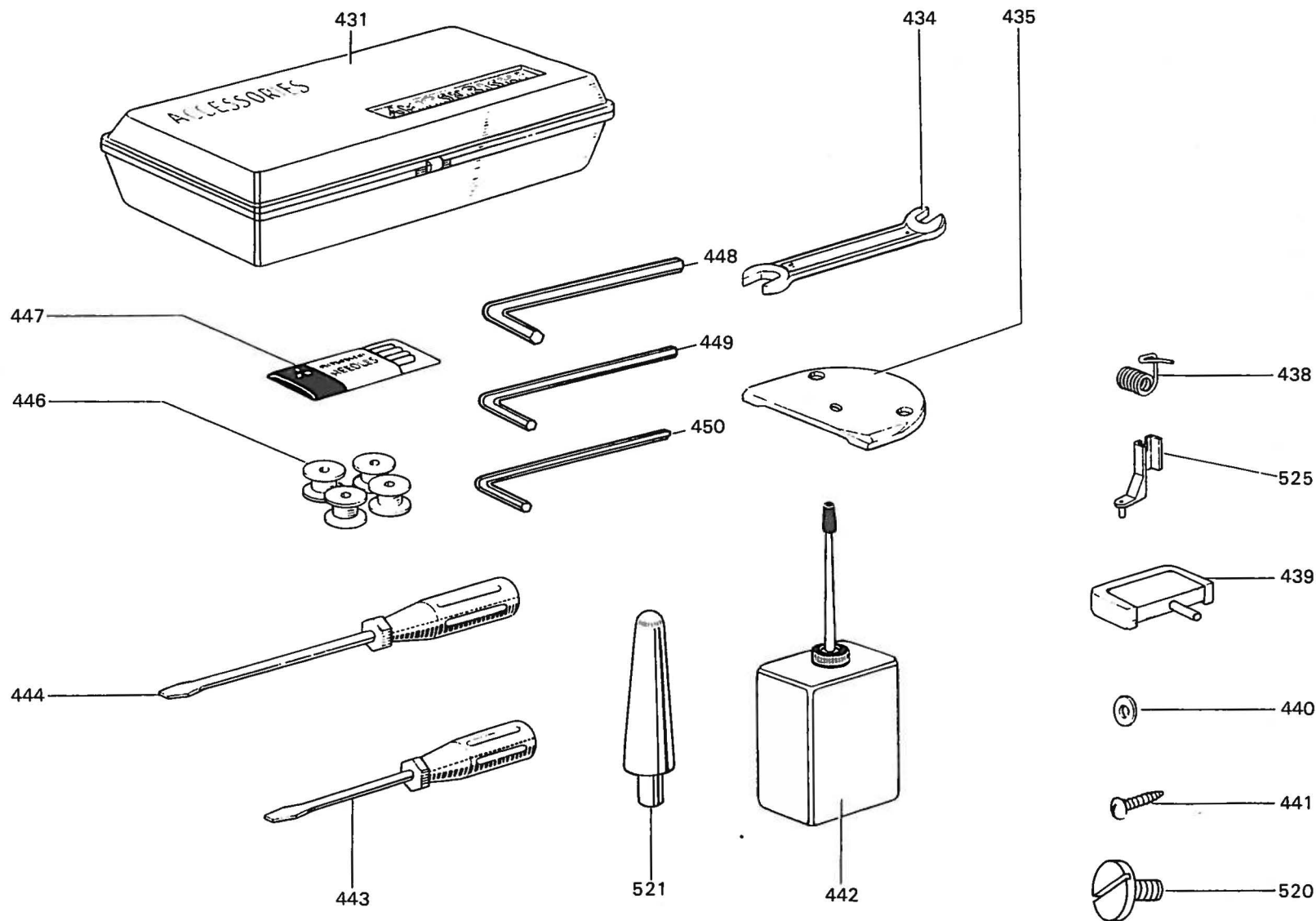

付属品箱関係

ACCESSORY BOX & ACCESSORIES

Fig. No.	部品コード Parts. No.	資材コード Ref. No.	部 品 名	Description	使用 個数 Amt. Req.	共通部品			Common Parts			
						IDY-349-22 BZ	IPV-2000-349	PLK-2520				
431	MF 60A0 749	P 833000X01	付 属 品 箱	Accessory box	1							
434	MM 10A1 479	B 422776H01	ス ハ ナ	Spanner	1							
435	MV 30A1 101	W349841H02	針 板 φ2	Needle plate	1							
438	MF 12B0 187	W486372H02	糸 取 り バ ネ	Thread take-up spring	1							
439	MF 70E0 418	W481678G01	ゴ ム ヒ ン ジ (組)	Table hinge with rubber cushion	2							
440	M9 0607 050	S 562131H04	ミ ガ キ 座 金 6	Washer 6	2							
441	M9 0401 041	S 519132H01	丸 木 ネ ジ 4.5×20	Screw 4.5×20	2							
442	MF 60A0 137	P 831001X01	油 差 シ	Oil with Oiler	1							
443	MB 02A1 608	P 842002X01	ド ラ イ バ ー (小)	Screw driver (Small)	1							
444	MB 02A0 608	P 842003X01	ド ラ イ バ ー (中)	Screw driver (Middle)	1							
446	MG 44B0 123	W470215HC2	ホ ビ ン	Bobbin	4							
447	MP 20B0 128	S 970005HC2	ミ シ ン 針 DP×17 #23	Needle DP×17 #23	4							
448	MF 90A0 976	W462660HC1	6 角 棒 ス ハ ナ 1 8"	Socket wrench 1 8	1							
449	MF 90A1 976	W488545HC2	6 角 棒 ス ハ ナ 2.5	Socket wrench 2.5	1							
450	MF 90A2 976	W488545H01	6 角 棒 ス ハ ナ 2	Socket wrench 2	1							
520	M9 5001 002	BE702D650H01	平 ネ ジ M12×10	Screw M12×10	4							
521	MF 40A0 426	P 999023X01	頭 部 支 工	Head supporter	1							
525	MV 30A1 256	A 130C201HJ2	押 工 (針穴φ2)	Presser foot	1							

PLK-2520

付属品関係  
OIL PAN & OTHER ACCESSORIES

PLK-2520

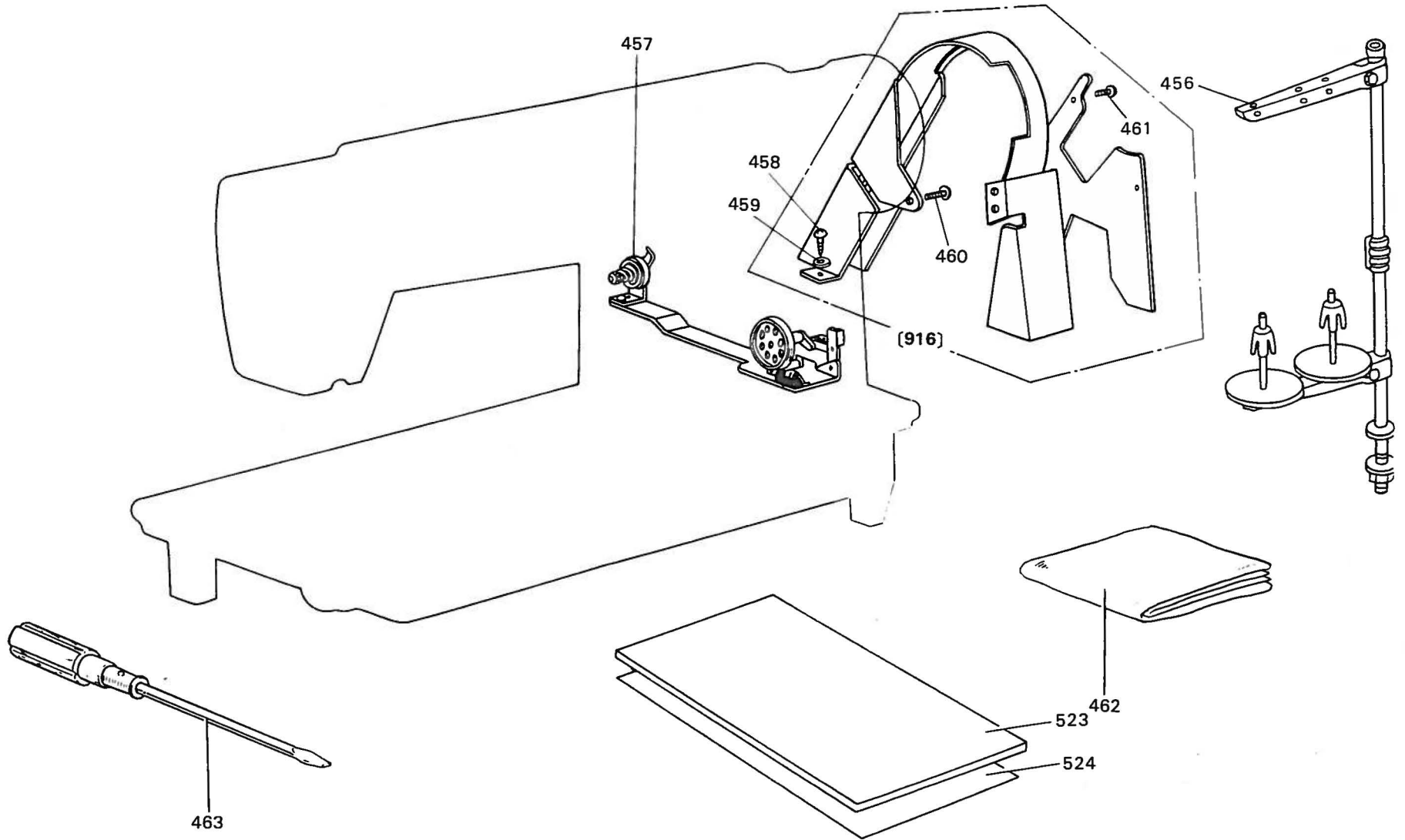

付属品関係

OTHER ACCESSORIES

Fig. No.	部品コード Parts. No.	資材コード Ref. No.	部 品 名	Description	使用 個数 Amt. Req.	共通部品 Common Parts							
						(DY-349-22-BZ)	(PV-2000-349)	PLK-2520					
456	MS 05E0 193	A190D080P01	糸 立 台 (組)	Cotton stand complete	1								
457	MF 67E0 190	P 992005X01	糸 巻 仕 掛	Bobbin winder complete	1								
458	M9 0401 041	S 519132H01	丸 木 ネジ 4.5×20	Screw 4.5×20	2								
459	M9 0607 050	S 562131H01	座 金 6	Washer M6	2								
460	M9 1506 004	W467868H02	フ ラ マ イ ネジ 15 64(28)×8	Screw 11 64(28)×8	3								
461	M9 1101 004	W466810H01	フ ラ マ イ ネジ 11 64(40)×8	Screw 11 64(40)×8	4								
916	MF 40E0 776	W341683G04	ベルトカバー (組)(国内用)	Belt cover	1								
462	MF 60A0 734	W220627H02	ビニールカバー	Polyethylene cover	1								
463	MF 60A0 608	W319408H01	ド ラ イ バ ー (大)	Screw drive (large)	1								
523	MV 30A0 437	WT90021X01	取 扱 説 明 書 (和文)	Instruction Manual									
523	MV 30A1 437	WT90022X02	取 扱 説 明 書 (英文)	Instruction Manual									
524	MV 30B0 437	BE702B793H01	付 属 品 一 覧 表	Accessory List									

PLK-2520

W. XY テーブル  
X. Y. TABLE MECHANISM

PLK-2520

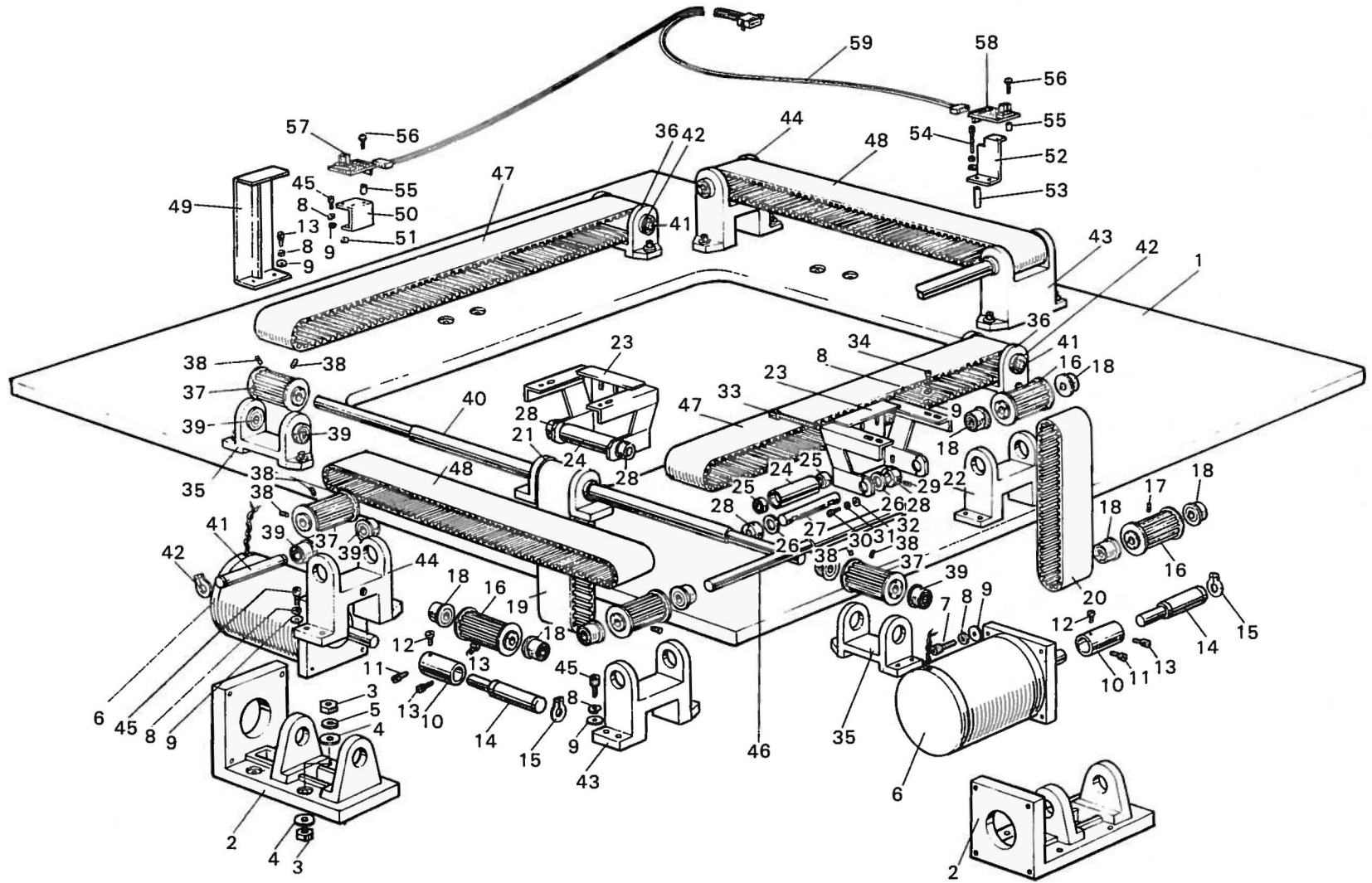

W. XY - ブル  
X.Y. TABLE MECHANISM

Fig. No.	部品コード Parts No.	資材コード R Ref. No.	部 品 名	Description	使用 個数 Amt. Req.	
W 1	MS 05A0 598	A110A066H01	X Y テーブル	XY Table	1	
W 2	MS 05A0 758	A120B112H01	ブラケット (モータ)	Bracket	2	
W 3	M9 2510 045	S910N010P10	ナット M10	Nut M10	16	
W 4	M9 1004 050	S913N060P10	サガネ 10	Washer 10	32	
W 5	M9 0107 053	S913N210P10	バネサガネ 10	Spring washer 10	24	
W 6	M9 5003 095		ステッピングモータ	Stepping motor	2	103-8932-1
W 7	M9 6007 021	S903N211P25	六角穴付ボルト M6×25	Bolt M6×25	8	
W 8	M9 0104 053	S913N210P06	バネサガネ 6	Spring washer 6	64	
W 9	M9 0551 050	S913N040P06	サガネ 6	Washer 6	64	
W10	MS 05A0 482	A140D801H01	スリーブ	Sleeve	2	
W11	M9 1602 006	E702D659H01	棒先平ネジ 1 4(40)	Screw 1 4(40)	2	
W12	M9 1602 002	W502703H01	平ネジ 1 4(40)×9	Screw 1 4(40)×9	2	
W13	M9 6006 021	S903N211P12	六角穴付ボルト M6×12	Bolt M6×12	20	
W14	MS 05A0 530	A140D800H01	段付軸	Shaft	2	
W15	M9 0520 065	S922N010P20	軸用C形止め輪 20	C-type stop ring	4	
W16	MS 05A0 767	A140D802H01	フーリ	Pulley	4	
W17	M9 6001 020	S901N310P06	六角穴付止メネジ M6×6	Screw M6×6	8	
W18	MS 05A0 456		深ミソ玉軸受	Ball bearing	8	6204ZZNR
W19	MS 05A0 523		タイミングベルト	Cog belt	1	T5-60-100
W20	MS 05A1 523		//	//	1	T5-60-110
W21	MS 05A1 758	A130C344H01	中間ブラケット	Bracket	1	
W22	MS 05A2 758	A130C344H02	//	//	1	
W23	MS 05A0 602	A120B167G01	フーリ取付金	Bracket	2	
W24	MS 05A0 352	A140D025H01	テンションフーリ	Tension pulley	2	
W25	MS 05A1 456		深ミソ玉軸受	Ball bearing	4	
W26	M9 1005 050	W501041H04	座金	Washer	4	
W27	MS 05A2 454	A140D026H01	軸	Shaft	2	
W28	MS 05A0 352	A140D027H01	カラ M5×10	Collar	4	
W29	M9 5001 020	S901N310P10	六角穴付止メネジ	Screw M5×10	8	
W30	M9 5002 021	S903N210P10	六角穴付ボルト M5×10	Bolt M5×10	8	
W31	M9 0550 050	S913N060P05	座金 5	Washer 5	16	
W32	M9 0501 053	S913N210P05	バネ座金 5	Spring washer 5	16	
W33	M9 6004 021	S903N211P55	六角穴付ボルト M6×55	Bolt M6×55	6	
W34	M9 6005 021	S903N211P22	// M6×22	Bolt M6×22	8	
W35	MS 05A3 758	A130C342H01	ブラケット (X)	Bracket (X)	2	
W36	MS 05A4 758	A130C342H02	// (//)	Bracket (X)	2	

PLK-2520

W. XY テーブル  
X. Y. TABLE MECHANISM

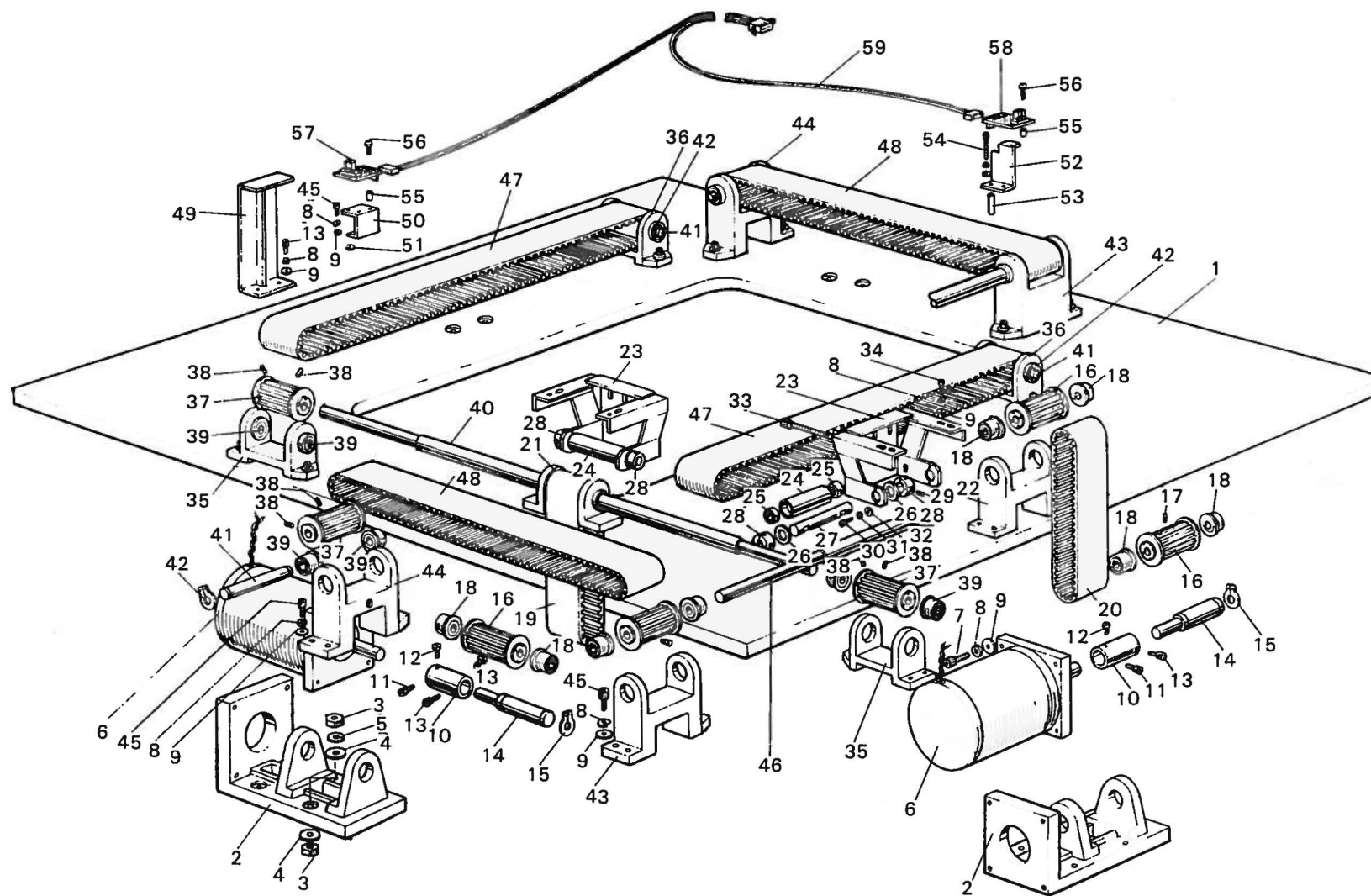



W. XY-ブル

X.Y.TABLE MECHANISM

Fig. No.	部品コード Parts. No.	資材コード Ref. No.	部 品 名	Description	使用 個数 Amt. Req.	
W37	MS 05A1 767	A140D804H01	プ ー リ	Polley	8	
W38	M9 5002 020	S901N310P06	六角穴付止メネジ M5×6	Screw M5×6	16	
W39	MS 05A0 456		深ミソ玉軸受	Ball bearing	16	6200ZZNR
W40	MS 05A1 390	A130C345H02	駆 動 軸	Shaft	1	
W41	MS 05A0 454	A140D803H01	軸	Shaft	4	
W42	M9 0510 065	S922N010P10	軸用C型止メ輪 10	C-type stop ring	8	
W43	MS 05A5 758	A130C343H01	ブ ラ ケ ッ ト (Y)	Bracket (Y)	2	
W44	MS 05A6 758	A130C343H02	// (//)	Bracket (Y)	2	
W45	M9 6003 021	S903N211P20	六角穴付ボルト M6×20	Bolt M6×20	34	
W46	MS 05A0 390	A130C345H01	駆 動 軸	Shaft	1	
W47	MS 05A3 523		タイミングベルト	Cog belt	2	T5-60-170
W48	MS 05A2 523		//	Cog belt	2	T5-60-145
W49	MS 05A2 601	A130C362H01	取 付 板 (ヒンジ)	Bracket (hinge)	2	
W50	MS 05A3 601	A140D809H01	取 付 板 (SWX)	Bracket (SWX)	1	
W51	MS 05A1 688	A140D810H02	パ イ プ	Pipe	2	
W52	MS 05A4 601	A140D811H01	取 付 板 (SWY)	Bracket (SWY)	1	
W53	MS 05A0 688	A140D810H01	パ イ プ	Pipe	2	
W54	M9 6002 021	S903N211P64	六角穴付ボルト M6×64	Bolt M6×64	2	
W55	MS 05A0 476	W488951H01	サ ポ ー ト	Support	6	
W56	M9 0332 037	S902N012P16	SW-PW付Pナベネジ M3×16	Screw M3×16	6	
W57	M9 1002 096	TE703P195G10	PLK-10-FSW×P板標摘	PC Board (X)	1	
W58	M9 5002 096	TE703P196G10	PLK-10-FSWY P板標摘	PC Board (Y)	1	
W59	M9 7111 099	E731D262G30	接続電線組立	Cable assembly	1	

PLK-2520

W. XY テーブル  
X. Y. TABLE MECHANISM

PLK-2520

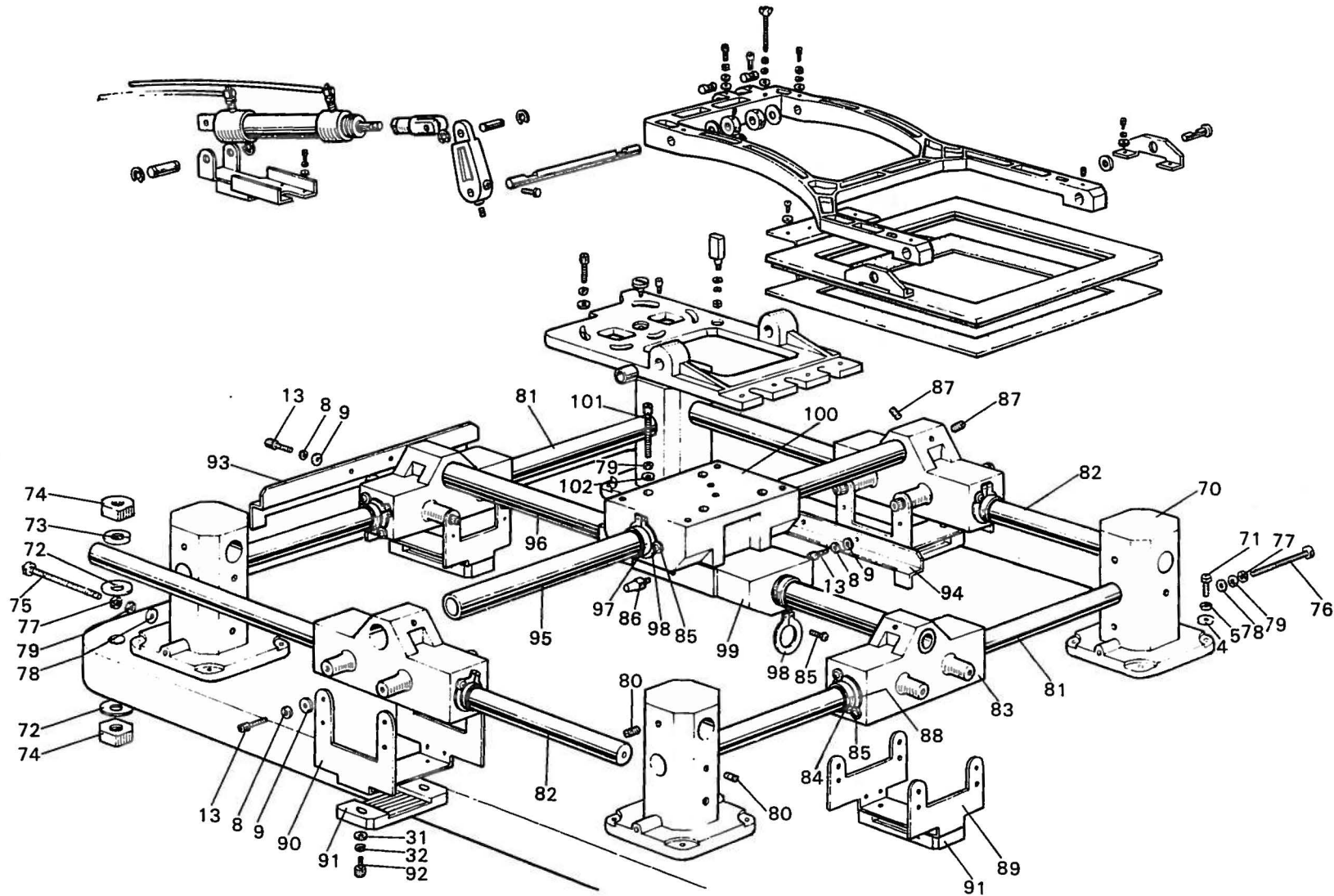

## X. Y. TABLE MECHANISM

Fig. No.	部品コード Parts. No.	資材コード Ref. No.	部 品 名	Description	使用 個個数 Amt. Req.	
W 70	MS 05B0 456	A120B119H01	ロッド受ケ	Rod support	4	
W 71	M9 1010 022	S903N013P50	六角ボルト M10×50	Bolt M10×50	16	
W 72	M9 2001 050	S913N060P20	ザガネ 20	Washer 20	8	
W 73	M9 0109 053	S913N210P20	バネザガネ 20	Spring Washer 20	4	
W 74	M9 5020 045	S910N010P20	ナット M20	Nut M20	8	
W 75	M9 8002 022		六角ボルト M8×100(全ねじ)	Bolt M8×100	2	
W 76	M9 8003 022		// M8×120( // )	Bolt M8×120	2	
W 77	M9 2008 045	S910N010P08	ナット M8	Nut M8	4	
W 78	M9 0801 050	S913N060P08	ザガネ 8	Washer 8	4	
W 79	M9 0108 053	S913N210P08	バネザガネ 8	Spring Washer 8	5	
W 80	M9 6002 020	S901N311P12	六角穴付止メネジ M6×12	Screw M6×12	8	
W 81	MS 05B0 975	A130C347H01	ロッド (S)	Rob (S)	2	
W 82	MS 05B1 975	A130C347H02	// (//)	Rob (S)	2	
W 83	MS 05B0 603	A130C348H01	移動台	Slider	4	
W 84	MS 05A0 628		L M ボール	Slide ball bearing	8	LM-20-U
W 85	M9 0333 037	S902N032P08	SW-PW付Pナベネジ M3×8	Screw M3×8	24	
W 86	MS 05A0 366	S930N411P01	グリースニッフル	Grease nipple	6	PS-PT1 8
W 87	M9 6001 021	S901N311P08	六角穴付ボルト M6×8	Bolt M6×8	8	
W 88	M9 0532 065	S922N010P32	軸用C形止メ輪 32	C-type stop ring	8	
W 89	MS 05A1 602	A130C350H01	ベルト取付金	Belt support	2	
W 90	MS 05A2 602	A130C350H02	ベルト取付金	Belt support	2	
W 91	MS 05A0 778	A140D807H01	ベルト押エ	Belt clamber	4	
W 92	M9 5001 021	S903N210P16	六角穴付ボルト M5×16	Bolt M5×16	8	
W 93	MS 05A1 339	A130C360H01	シャヘイ板 (X)	Detector plate(X) plate (X)	1	
W 94	MS 05A2 339	A130C361H01	シャヘイ板 (Y)	Detector plate(Y)	1	
W 95	MS 05A0 975	A130C346H01	ロッド (L)	Rod (L)	1	
W 96	MS 05A1 975	A130C346H02	ロッド (L)	Rod (L)	1	
W 97	MS 05A1 628		L M ボール	LM-30-U	4	LM-30-U
W 98	M9 0545 065	S922N010P45	軸用C形止メ輪 45	Slide ball bearing	4	
W 99	MS 05A0 603	A130C349H01	X Y 可動台 (下)	X-Y Movable bracket (upper)	1	
W100	MS 05A1 603	A120B099H01	X Y 可動台 (上)	X-Y Movable bracket (lower)	1	
W101	M9 8003 021	S903N212P55	六角穴付ボルト M8×55	Bolt M8×55	4	
W102	M9 0801 050	S913N010P08	小座金 8	Small Washer 8	4	

PLK-2520

P. 外押え関係  
WORK HOLDER MECHANISM

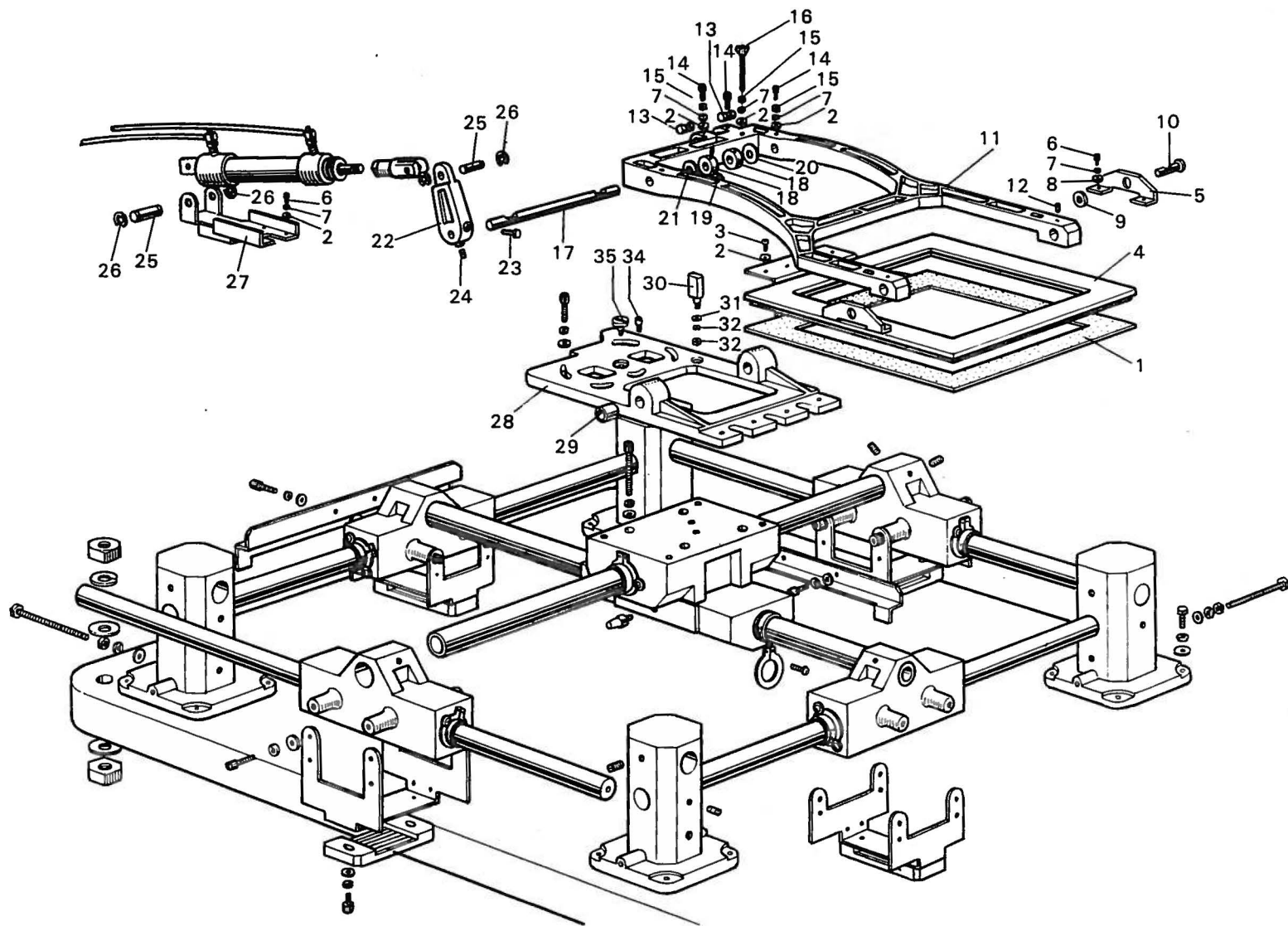

P. 外掛関係

WORK HOLDER MECHANISM

Fig. No.	部品コード Parts. No.	資材コード Ref. No.	部品名	Description	使用 個数 Amt. Req.
P 1	MS 05A0 257	A120B106G30	下 押 え 板 (1)	Lower clamp frame (1)	1
P 2	M9 0552 050	S913N060P05	座 金 5	Washer 5	9
P 3	M9 0504 037	S900N210P08	P ト ラ ス ネジ M5×10	Screw M5×10	4
P 4	MS 05A0 254	A120B104G30	上 押 え 板 (1)	Upper clamp frame (1)	1
P 5	MS 05B1 456	A140D822H01	軸 受 板	Shaft support plate	2
P 6	M9 5003 021	S903N210P12	六角穴付ホルト M5×12	Bolt M5×12	8
P 7	M9 0501 053	S913N210P05	バネザガネ 5	Spring washer 5	13
P 8	M9 0550 050	S913N010P05	小 座 金 5	Small washer 5	8
P 9	M9 1005 050	W501041H04	座 金	Washer	2
P10	MS 05A1 530	A140D823H01	段 付 軸	Shaft	2
P11	MS 05A0 308	A110A077H01	押 え 取 付 枠	Clamp frame	1
P12	M9 6002 020	S901N310P06	六角穴付止メネジ M5×6	Screw M5×6	2
P13	M9 0803 060	A140D819H01	ピン φ12×21	Pin φ12×21	2
P14	M9 5001 021	S903N210P16	六角穴付ホルト M5×16	Bolt M5×16	4
P15	M9 1373 045	S910N010P05	ナ ッ ト M5	Nut M5	3
P16	M9 5001 025	S903N535P40	蝶 ボ ル ト M5×40	Thumb bolt	1
P17	MS 05A3 454	A130C351H01	外 押 え 回 転 軸	Shaft	1
P18	MF 70A0 352	W476422H01	カ ラ ー	Collar	2
P19	M9 1602 001	W500036H01	止 メ ネ ジ 1 4(40)×4	Screw 1 4(40)×4	4
P20	M9 8003 050	A140D029G01	座 金 25×15×3t	Washer 25×15×3t	1
P21	M9 8004 050	A140D029G02	座 金 25×15×3.1t	Washer 25×15×3.1t	1
P22	MS 05A0 950	A140D821H01	外 押 え レ バ ー	Lever	1
P23	M9 1802 006	B503851H01	棒 先 平 ね じ 9 32(28)	Screw 9 32(28)	1
P24	M9 1801 001	B509058H01	止 め ね じ 9 32(28)×6	Screw 9 32(28)×6	1
P25	MV 30A0 454	E702D610H01	軸	Shaft	2
P26	M9 0511 065	S922N210P60	E 形 止 メ 輪	E-type stop ring	4
P27	MS 05A5 601	A140D818H01	取 付 板 (シリンダー)	Bracket (Cylinder)	1
P28	MS 05A2 603	A120B100H01	下 押 え 取 付 台	Base	1
P29	MS 05A0 750	A140D816H01	ブ ッ シ ュ	Bush	2
P30	MS 05A4 454	A140D817H01	特 殊 軸	Shaft	1
P31	M9 0811 050	S913N040P08	座 金 8	Washer 8	1
P32	M9 0108 053	S913N210P08	ば ね 座 金 8	Spring washer 8	1
P33	M9 2008 045	S910N010P08	ナ ッ ト M8	Nut M8	1
P34	M9 8001 033	A140D805H01	ピ ン ネ ジ M8	Pin Screw M8	1
P35	M9 8001 015	A140D806H01	段 付 平 ネ ジ M8	Screw M8	1

PLK-2520

テーブル本体  
TABLE MECHANISM

PLK-2520

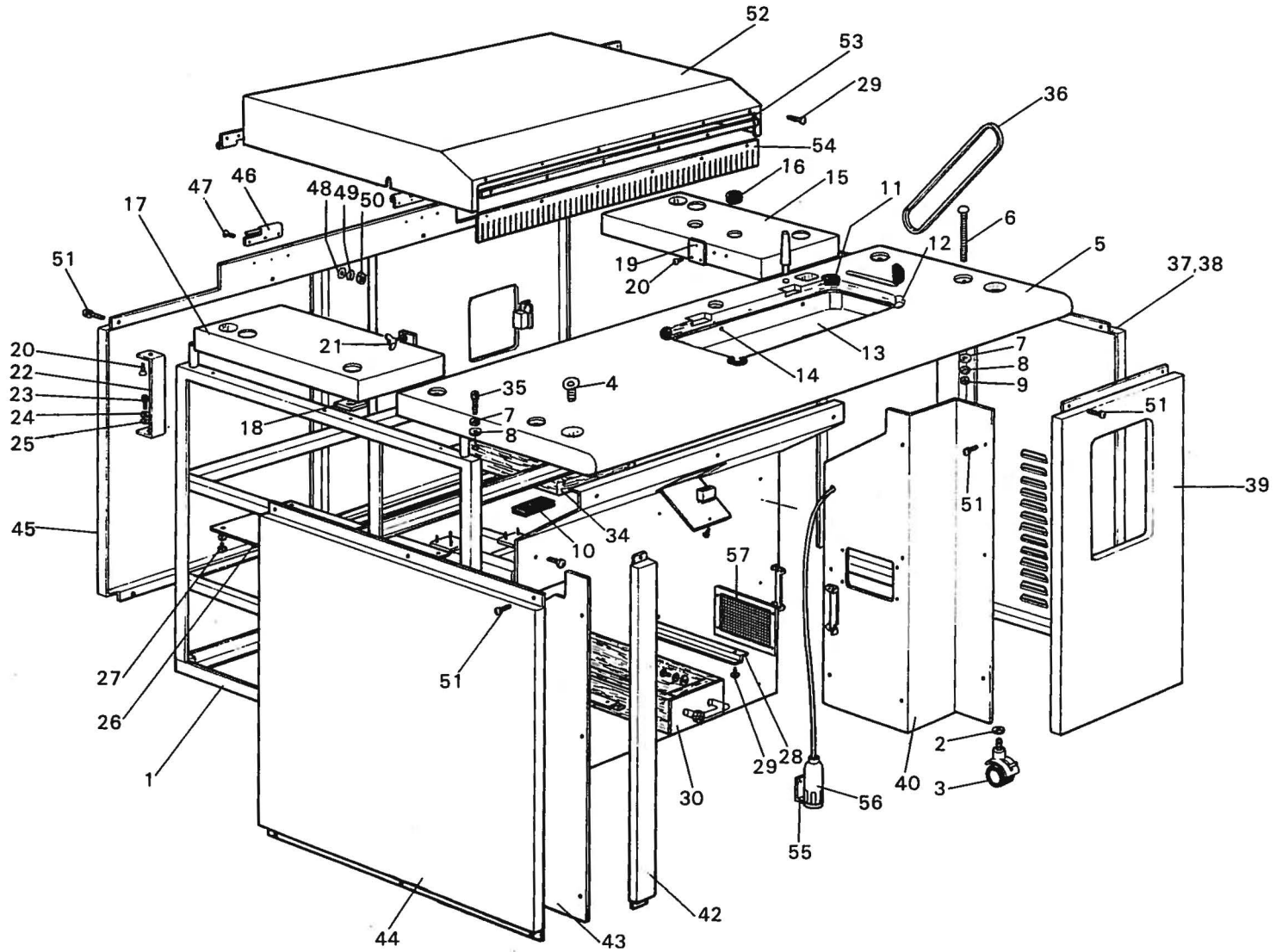

T. テーブル本体

TABLE MECHANISM

Fig. No.	部品コード Parts. No.	資材コード Ref. No.	部品名	Description	使用 個数 Amt. Req.	
T 1	MS 05E0 374	A120B091G01	機 枠 組 立	Frame Assembly	1	
T 2	M9 1012 053	S913N210P12	バ ネ 座 金 12	Spring washer 12	7	
T 3	MS 05E0 972		キ ャ ス タ M12	Caster M12	7	
T 4	M9 2212 031	S904N310P12	ア イ ボ ル ト M12	Eye bolt M12	4	
T 5	MS 05A0 595	A120B093H01	天 板	Table top (Middle)	1	
T 6	M9 8004 022	M904Z514H03	取 付 ボ ル ト M8×70	Bolt M8×70	9	
T 7	M9 0108 053	S913N210P08	バ ネ 座 金 8	Spring washer 8	13	
T 8	M9 0811 050	S913N040P08	座 金 8	Washer 8	13	
T 9	M9 2008 045	S910N010P08	ナ ッ ト M8	Nut M8	13	
T10	MS 05A0 419	A140D790H01	防 振 ゴ ム	Cushion rubber	6	
T11	MG 40B1 419	W481655H01	防 振 ゴ ム (小)	Cushion rubber (small)	2	
T12	MG 40B0 419	W481654H01	防 振 ゴ ム (大)	Cushion rubber (large)	2	
T13	MS 05A0 131	A130C334G01	油 受 (組)	Oil resevoir	1	
T14		S817001H02	釘 N25	Nail N25	6	
T15	MS 05A1 595	A130C332H01	天 板 (右)	Table top (Light)	1	
T16	MS 05A0 416	S935Z040H13	Eホゴブッシュ	E-protective bushing	1	
T17	MS 05A2 595	A130C333H01	天 板 (左)	Table top (Left)	1	
T18	MS 05A1 476	A140D791H01	ス ペ ー サ	Spacer	4	
T19	MS 05A6 601	A140D792H01	取 付 板 (XYカバー)	Bracket (XY cover)	2	
T20	M9 0400 041	S908N156P16	丸 木 ネ ジ 4.1×16	Screw 4.1×16	6	
T21	M9 4001 023	S903N534P08	蝶 ボ ル ト M4×8	Thumb bolt M4×8	2	
T22	MS 05A0 429	A140D794H01	天 板 支 工 板	Support	2	
T23	M9 5003 021	S903N210P12	六 角 穴 付 ボ ル ト M5×12	Bolt M5×12	4	
T24	M9 0501 053	S913N210P05	バ ネ 座 金 5	5 Spring washer	6	
T25	M9 0550 050	S913N040P05	座 金 5	5 Washer	6	
T26	MS 05A7 601	A130C337H01	取 付 板 (引出し)	Bracket	1	
T27	M9 0502 037	S902N035P10	SW-PW付Pナベネジ M5×10	Screw M5×8	4	
T28	MS 05A0 957	A140D795H01	レ ー ル	Rail	2	
T29	M9 0333 037	S902N032P08	SW-PW付Pナベネジ M3×8	Screw M3×10	10	
T30	MS 05E0 719	A130C338H01	引 出 し	Drawer	1	
T34	MS 05A0 850	A130C336H01	モ ー タ ダ イ	Motor base plate	1	A-42-C-7
T35	M9 8002 021	S903N212P66	六 角 穴 付 ボ ル ト M8×66	Bolt M8×66	4	4-42-B-7
T36	MS 05A0 777		V ベ ル ト	V belt	1	

M57

PLK-2520

テーブル本体  
TABLE MECHANISM

PLK-2520

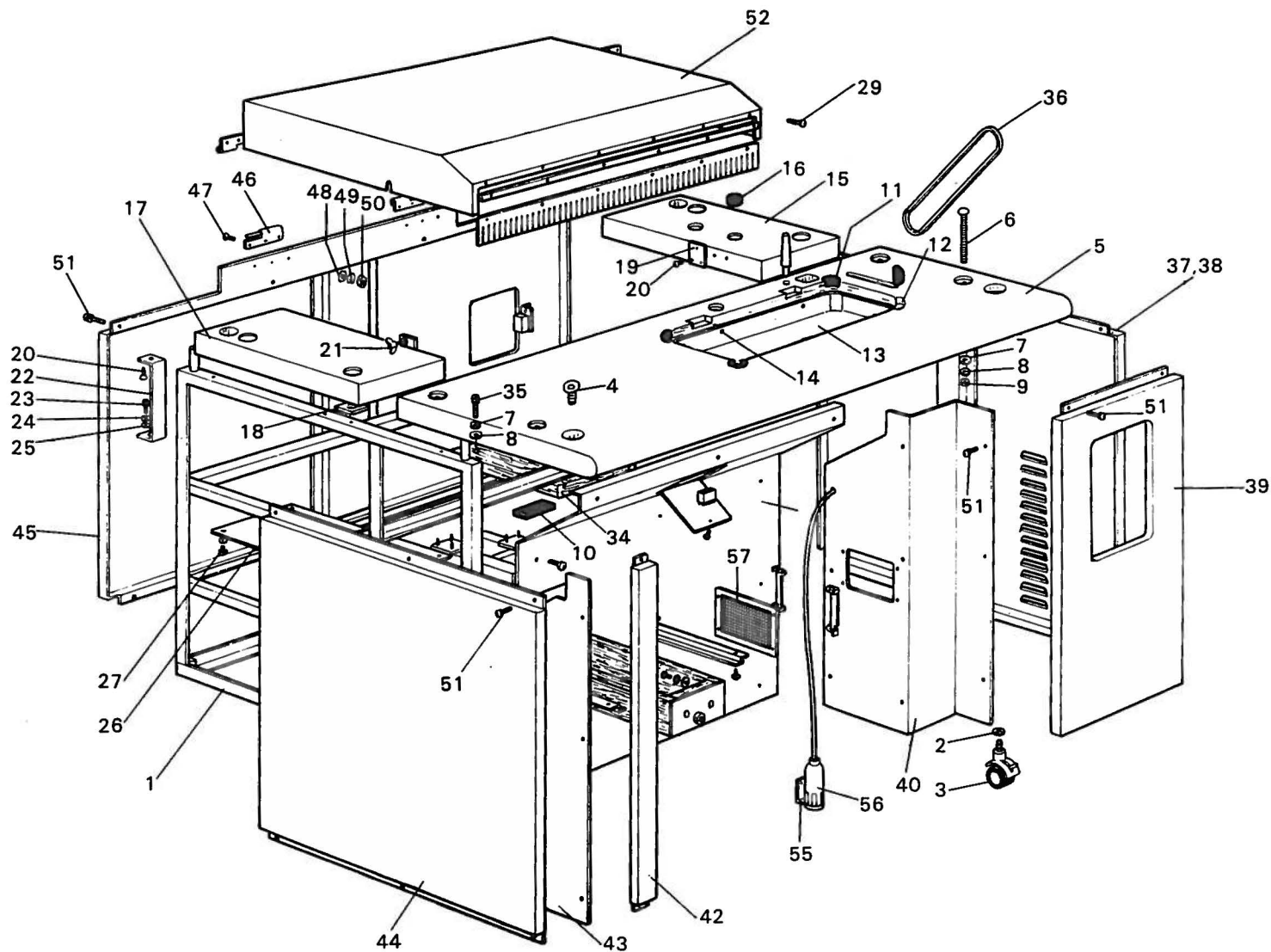



# T. テーブル本体

## TABLE MECHANISM

Fig. No.	部品コード Parts. No.	資材コード Ref. No.	部 品 名	Description	使用 個数 Amt. Req.	
T37	MS 05A3 339	A120B097G01	カ バ ー (右外)	Cover	1	
T38	MS 05A1 750	S935Z013H01	A保護ブッシュ	A-protective bushing	1	
T39	MS 05T0 339	A120B110G01	カ バ ー (前右)	Cover	1	
T40	MS 05T4 339	A130C341H01	カ バ ー (右内)	//	1	
T41	MS 05T1 339	A120B098G01	カ バ ー (前内)	//	1	
T42	MS 05T5 339	A130C339H01	カ バ ー (左前)	//	1	
T43	MS 05T6 339	A130C340H01	カ バ ー (左内)	//	1	
T44	MS 05T2 339	A120B096G01	カ バ ー (左外)	//	1	
T45	MS 05T3 339	A120B095G01	カ バ ー (後)	//	1	
T46	MS 05A0 560	A140D876P01	蝶 番	Hinge	2	
T47	M9 0830 004	S900N313P10	十字穴付小ネジ M3×10	Screw M3×10	12	
T48	M9 0313 050	S913N040P03	座 金 3	Washer 3	12	
T49	M9 0302 053	S913N210P03	バ ネ 座 金 3	Spring washer 3	12	
T50	M9 0873 045	S910N010P03	ナ ッ ト M3	Nut M3	12	
T51	M9 0502 037	S902N035P10	SW-PW付Pナベネジ M5×10	Screw M5×10	50	
T52	MS 05E0 339	A120B094G01	カ バ ー (XYテーブル)	Cover	1	
T55	MV 30A0 131	E702D598H01	油 受 台	Oil support bracket	1	
T56	MF 20A0 130	W319422H01	油 ビ ン	Oiler	1	
T57	MS 05E1 337		フ ィ ル タ	Filter	1	A-20型フィルタキット

PLK-2520

A. モートル部分  
MOTOR

PLK-2520

A

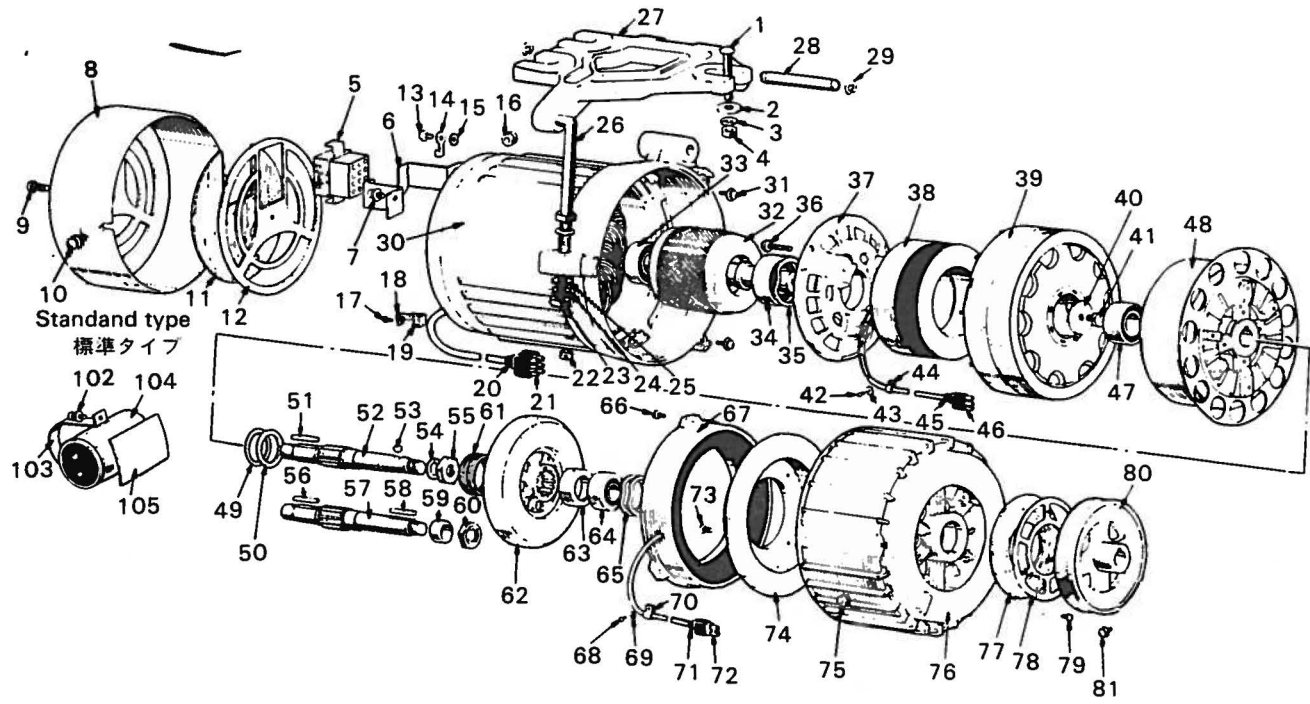

A. モーター部分  
MOTOR

Fig. No.	部品コード Parts. No	資材コード Ref. No.	部 品 名	Description	使用 個数 Amt. Req.	共通部品 Common Parts														
A 1	K11M90451403	BM904Z514H03	取付ボルト M8×70	Mounting Bolt M8×70	3															
A 2	K11M91490801	BM914D908H01	特殊座金	Wide-Rimmed Washer	3															
A 3	K10S 91321008	BS 913N210P08	ばね座金 8	Spring Washer 8	3															
A 4	K10S 91001008	BS 910N010P08	ナット M8	Nut M8	3															
A 5	K11M94313601	BM943D136P01	逆転プラグ受	Reverse Rotation Socket	1															
A 6	K11M98715802	BM987D158H02	取付板	Adapter	1															
A 7	K10S 90203408	BS 902N034P08	SW・PW付Pなべねじ M4×0.7×8	P-Screw with SW & PW M4×0.7×8	2															
A 8	K11M96894903	BM968B949H03	端カバー (標準タイプ)	End Cover (Standard Type)	1															
A 9	K10S 90001506	BS 900N015P06	Pなべねじ M5×0.8×6	P-Screw M5×0.8×6	1															
A10	K10S 90203408	BS 902N034P08	SW・PW付Pなべねじ M4×0.7×8	P-Screw with SW & PW M4×0.7×8	2															
A11	K11M98480001	BM984C800H01	フィルター	Filter	1															
A12	K11M98394205	BM983C942H05	押え板	Filter Keeping Plate	1															
A13	K10S 90041408	BS 900N414P08	P黄銅なべねじ M4×0.7×8	P-BS-Screw M4×0.7×8	1															
A14	K10S 94001040	BS 940N010P40	裸丸圧着端子 1.25-F4	Terminal 1.25-F4	2															
A15	K10S 91502004	BS 915N020P04	歯付座金 B4	Toothed Lock Washer B4	1															
A16	K10S 93501207	BS 935Z012P07	A保護ブッシュ 6.3×4.5	Protective Bushing 6.3×4.5	1															
A17	K10S 90001404	BS 900N014P04	Pなべねじ M4×0.7×4	P-Screw M4×0.7×4	2															
A18	K11M95621902	BM956D219H02	締付金具	Fittings	1															
	K11M93504401	BM935Z044H01	保護ブッシュ (標準)	Protective Bushing (Standard)	1															
A19	K11M93504402	BM935Z044H02	保護ブッシュ (単相2重電圧)	Protective Bushing (1φ Dual Voltage)	1															
	K11M93504403	BM935Z044H03	保護ブッシュ (三相2重電圧)	Protective Bushing (3φ Dual Voltage)	1															
A20	K11M96823501	BM968Z235P01	ナイロンキャップ 3191-06R1用	Nylon Cap	1															
	K10S 95024564	BS 950N245P64	コネクタ 3191-06R1(白)	Connector 3191-06R1 (White)	1															
A21	K10S 95024581	BS 950N245P81	コネクタ 3191-06R1-BU(青)	Connector 3191-06R1-BU (Blue)	1															
	K10S 95024582	BS 950N245P82	コネクタ 3191-06R1-BL(黒)	Connector 3191-06R1-BL (Black)	1															
A22	K10S 93501207	BS 935Z012P07	A保護ブッシュ 6.3×4.5	Protective Bushing 6.3×4.5	1															
A23	K10S 91001010	BS 910N010P10	ナット M10	Nut M10	2															
A24	K10S 91321010	BS 913N210P10	ばね座金 10	Spring Washer 10	1															
A25	K10S 91304010	BS 913N040P10	座金 10	Washer 10	2															
A26	K11M98501202	BM985C013H02	調整ボルト	Adjusting Bolt	1															
A27	K11M9781272122M	BM978A127H2122	ベース	Base	1															
A28	K11M92187501	BM921Z875H01	ベースピン	Base-Pin	1															
A29	K10S 92221090	BS 922N210P90	E形止め輪 9	E-Ring 9	2															
A30	K11M99999999	※	フレーム&ステータ組立	Frame & Stator Assembly	1															
A31	K11M90291980	BM902D919G80	締付ねじ	Fitting Screw	3															
A32	K11M99999999	※	ロータ (シャフト付)	Rotor (With Shaft)	1															

PLK-2520

A. モートル部分  
MOTOR

PLK-2520

A

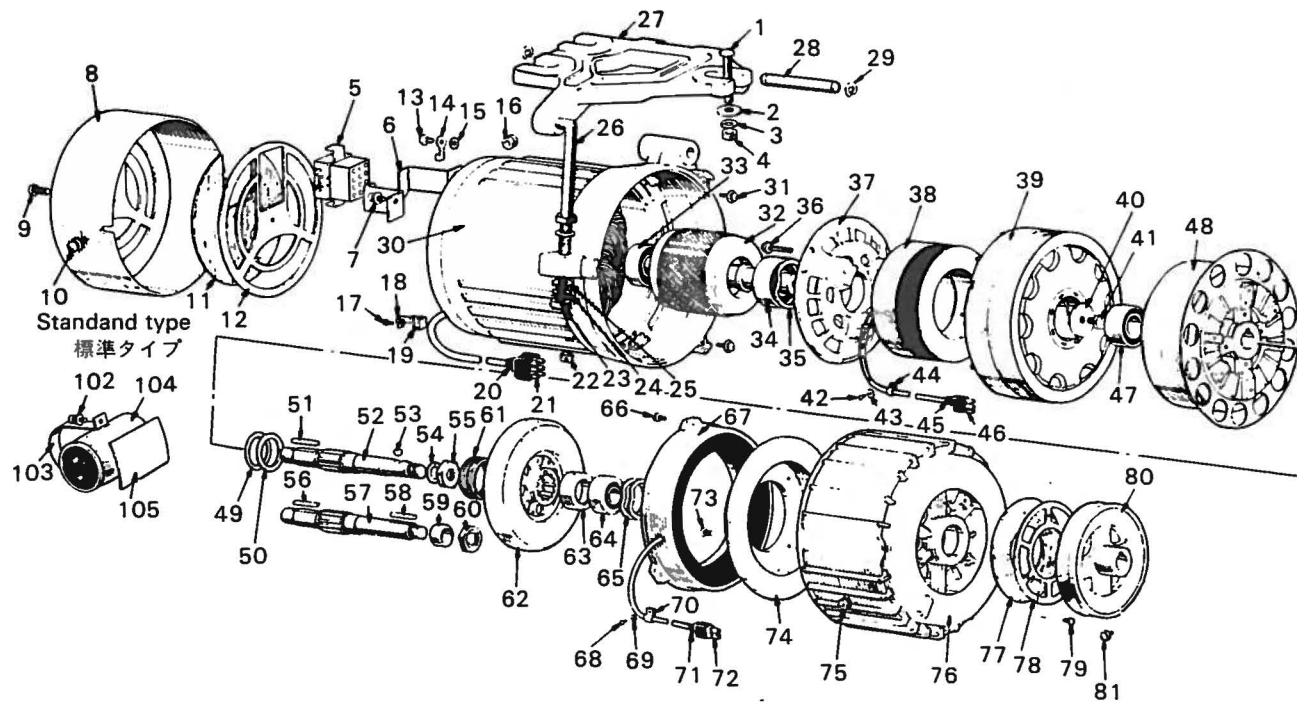

A. モーター部分  
MOTOR

Fig. No.	部品コード Parts. No	資材コード Ref. No.	部 品 名	Description	使用 個数 Amt. Req.	共通部品 Common Parts			
A33	K10S 86203209	BS 862N032P09	シールドボールベアリング #6203	Sealed Ball Bearing #6203	1				
A34	K10S 86204200	BS 862N042P00	シールドボールベアリング #6204	Sealed Ball Bearing #6204	1				
A35	K11M96281647	BM962Z816H47	プレロードスプリング	Preload Spring	1				
A36	K10S 90201520	BS 902N015P20	SW付Pなべねし M5×0.8×20	P-Screw with SW M5×0.8×20	3				
A37	K11M38212421	BM382B124H21	中間ブラケット	Middle Bracket	1				
A38	K11M09021401	BM090B214H01	クラッチコイル組立	Clutch Coil Assembly	1				
A39	K11M99999999	+	ドライブメンバー組立	Drive-Member Assembly	1				
A40	K11M91397903	BM913D979H03	特殊座金	Wide-Rimmed Washer	1				
A41	K10S 90201614	BS 902N016P14	SW付Pなべねし M6×14	P-Screw with SW M6×14	1				
A42	K10S 90001408	BS 900N014P08	Pなべねし M4×0.7×8	P-Screw M4×0.7×8	1				
A43	K10S 91304004	BS 913N040P04	座金 4	Washer 4	1				
A44	K10S 94522004	BS 945N220P04	ナイロンクリップ HP-4N	Nylon Clip Hp-4N	1				
A45	K11M96823502	BM968Z235P02	ナイロンキャップ 3191-03R1用	Nylon Cap	1				
A46	K10S 95024562	BS 950N245P62	コネクター 3191-03R1	Connector 3191-03R1	1				
A47	K10S 86302273	BS 863N022P73	シールドボールベアリング #6302	Sealed Ball Bearing #6302	1				
A48	K11M09021403	BM090B214H03	ドライブメンバー組立	Driven-Member Assembly	1				
A49	K11M91492502	BM914D925H02	ワッシャー t1.0	Washer t1.0	1				
A50	K11M91370406	BM913Z704H06	ワッシャー t0.25	Washer t0.25	a few				
A51	K10S 92514120	BS 925N141P20	キー 5×5×20	Key 5×5×20	1				
A52	K11M97103005	BM971C030H05	クラッチ軸 (テーパ)	Clutch Shaft (taper)	1				
A53	K10S 92531413	BS 925N314P13	半月キー 4×13	Woodruff Key 4×13	1				
A54	K10S 91321010	BS 913N210P10	ばね座金 10	Spring Washer 10	1				
A55	K11M91025401	BM910D254H01	ナット M10×1	Nut M10×1	1				
A56	K10S 92514120	BS 925N141P20	キー 5×5×20	Key 5×5×20	1				
A57	K11M97103104	BM971C031H04	クラッチ軸 (ストレート)	Clutch Shaft (straight)	1				
A58	K11M92554002	BM925Z540H02	キー 5×5×24	Key 5×5×24	1				
A59	K11M91726603	BM917D266H03	カラ	Collar	1				
A60	K10S 91169012	BS 911N690P12	U-ナット M12	U-Nut M12	1				
A61	K11M92712802	BM927D128H02	ブレーキばね	Coil Spring	1				
A62	K11M08226380	BM082D263G80	可動板	Armature (lining)	1				
		BM033C560B00	(ライニング加工区)						
A63	K11M96823003	BM968D230H03	キャップ	Cap	1				
A64	K10S 86202209	BS 862N022P09	シールドボールベアリング #6202	Sealed Ball Bearing #6202	1				
A65	K11M96280035	BM962Z800H35	プレロードスプリング	Preload Spring	2				
A66	K10S 90201416	BS 902N014P16	SW付Pなべねし M4×0.7×16	P-Screw with SW M4×0.7×16	3				
A67	K11M72045080	BM720C450G80	固定コア組立	Core Assembly	1				

PLK-2520

A. モートル部分  
MOTOR

PLK-2520

A

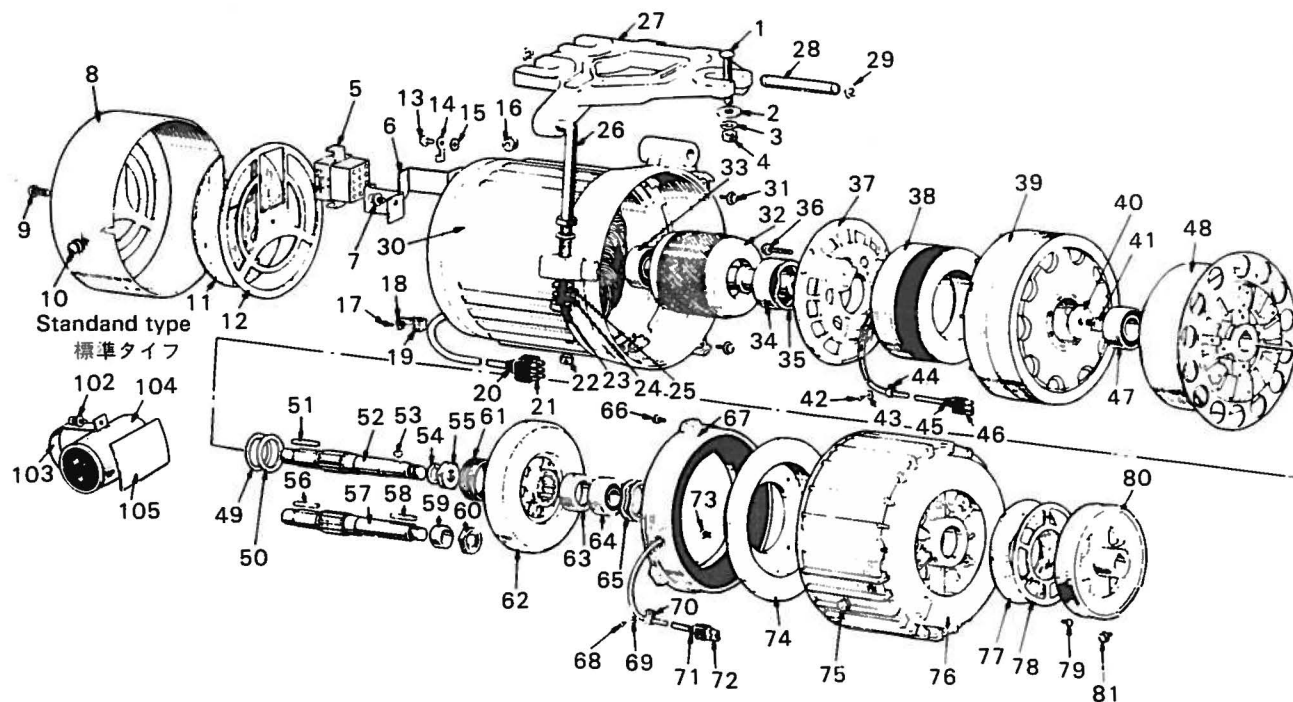

A. モーター部分  
MOTOR

Fig. No.	部品コード Parts. No.	資材コード Ref. No.	部 品 名	Description	使用 個数 Amt. Req.	共通部品		Common Parts	
A 68	K10S 90001408	BS 900N014P08	P な へ ね じ M4×0.7×8	P-Screw M4×0.7×8	1				
A 69	K10S 91304004	BS 913N040P04	座 金 4	Washer 4	1				
A 70	K10S 94522004	BS 945N220P04	ナイロンクリップ HP-4N	Nylon Clip HP-4N	1				
A 71	K11M96823503	BM968Z235P03	ナイロンキャップ 3191-02R1用	Nylon Cap	1				
A 72	K10S 95024561	BS 950N245P61	コネクタ 3191-02R1	Connector 3191-02R1	1				
A 73	K10S 90011414	BS 900N115P14	P 皿 ね じ M5×0.8×14	P-Counter-Sunk Screw M5×0.8×14	4				
A 74	K11M72125741	BM721C257H41	ブレーキ板	Brake Disc	1				
A 75	K10S 93501207	BS 935Z012P07	A保護ブッシュ 6.3×4.5	Protective Bushing 6.3×4.5	1				
A 76	K11M38212342	BM382A123H42	P側ブラケット	Load Side Bracket	1				
A 77	K11M98483502	BM984D835H02	フィルター	Filter	1				
A 78	K11M98707402	BM987D074H02	押 え 板	Filter Keeping Plate	1				
A 79	K10S 90201408	BS 902N014F08	SW Pなへねじ M4×0.7×8	P-Screw with SW M4×0.7×8	3				
A 80	K11M99999999	BS ※	プ ー リ (テーパ)	Pulley (taper)	1				
A102	K10S 90203408	BS 902N034P08	SW・PW付Pなへねじ M4×0.7×8	P-Screw with SW & PW M4×0.7×8	2				
A103	K11M41083001	BB V41083H01	取 付 板 25μF 230WV	Adapter Plate	1				
A104	K10S 11882501	BS 118Z825P01	コンデンサ 25μF 230WV	Capacitor 25μF 230WV	1				
A105	K11M95884601	BM958D846H01	絶 縁 板	Insulation Sheet	1				
<p>注 意：※、印部品についてはモートル形名、電圧、周波数、顧客名等をお知らせください。          印部品(A32, A39)は同時供給です。個々に供給はいたしません。          ※印部品(テーパプーリ)についてはプーリ外径をお知らせください。          A102~A105は単相400W 2P用です。他の単相機種についてはモートル形名をお知らせください。</p>									
<p>Note : ※, -mark; please send us the informations of motor (model name, voltage, frequency) and country name (customer name).          -mark (A32, A39) : the parts is not available for supply one by one. however, the parts can be ordered together.          ※-mark; please send us the information of pulley (taper) - outer diameter.          A102~A105; for single phase (1 2 Hp 2 poles) only. other type; please send us the informations of motor (model name, voltage, frequency).</p>									

PLK-2520

# C. 制御関係 CONTROLE MECHANISM

PLK-2520

## C-1. 制御盤 C

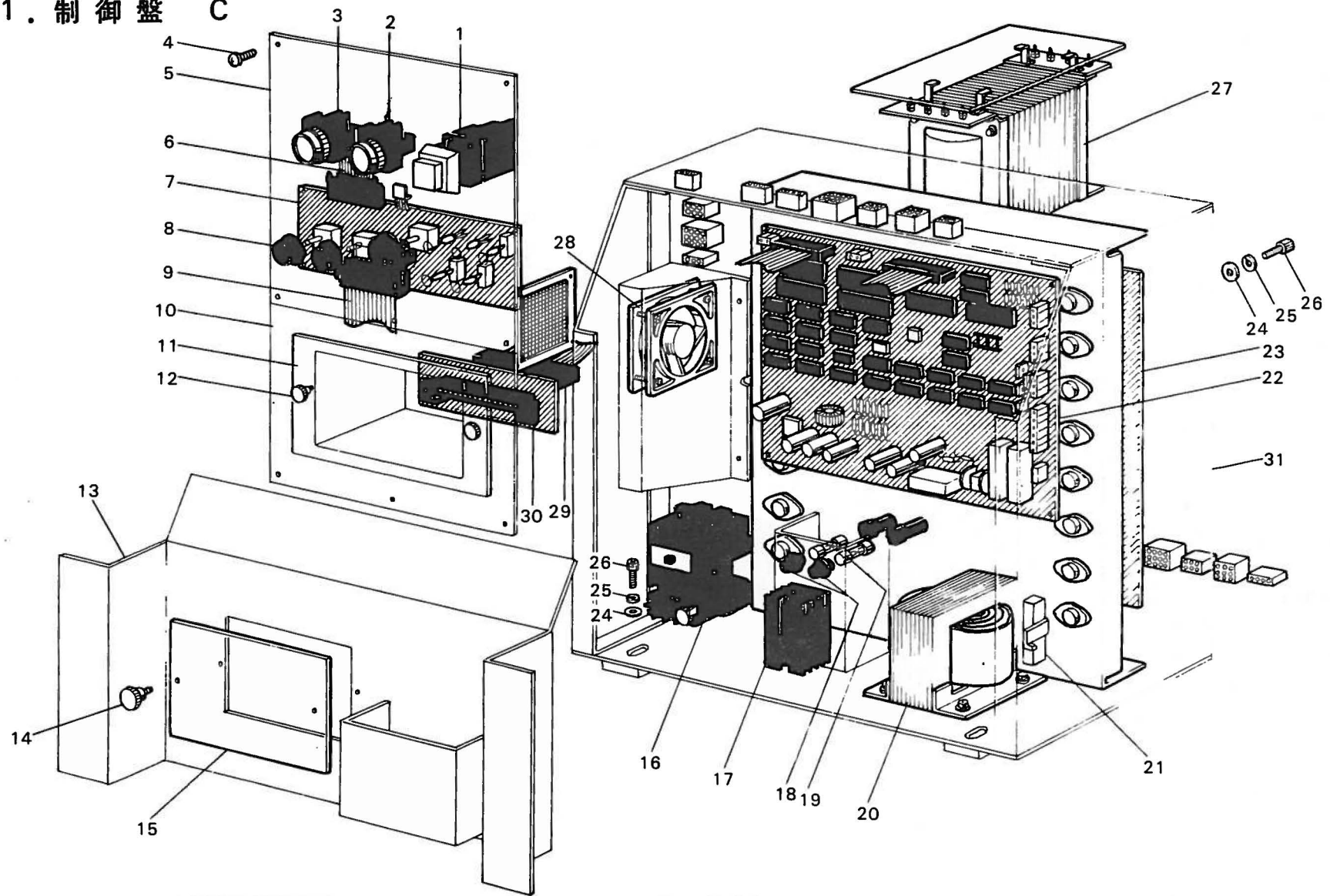



C. 制御係  
C-1. 制御盤

CONTROLE MECHANISM

Fig. No.	部品コード Parts. No.	資材コード Ref. No.	部 品 名	Description	使用 個数 Amt. Req.	
C 1	M9 0606 099		表示ランプ	Pilot lamp	1	PA-2-SG-T1
C 2	M9 1002 090		スイッチ	Switch	1	OR-2-GG-1A
C 3	M9 1003 090		スイッチ	Switch	1	OR-2-GR-1B
C 4	M9 0410 037	BS902N034P08	P ナベネジ M4×8	Screw M4×8	8	
C 5	MS 05A0 844	BE702B973H01	表示名板	Plate	1	
C 6	M9 7120 099	BE702D260G31	接続電線組立	Cable assembly	1	
C 7	M9 6008 096	TE703P188G10	プリント板組立	PC Board	1	PLK-20-PAL
C 8	MS 05A0 573	BS937N521P17	ツマミ	Knob	3	CM-15S
C 9	M9 7122 099	BE703D265G30	接続電線組立	Cable assembly	1	
C10	MS 05A0 800	BE703B421G01	前板	Panel assembly	1	
C11	MS 05A0 742	BE703D300H01	フタ	Cover	1	
C12	M9 1005 035	BS901Z610H11	細首ツマミネジ M4×0.7×8	Screw M4×0.7×8	2	
C13	MS 05E0 339	BE731B440G01	前板組立	Cover	1	
C14	M9 1003 035	BS901Z610H01	細首ツマミネジ M3×0.5×8	Screw M3×0.5×8	2	
C15	MS 05A1 742	BE731D300H01	フタ	Cover	1	
C16	M9 1005 090		マグネットスイッチ	Magnet switch	1	
C17	M9 4001 093	BE703D043G02	A V R 組立 (定電圧電源)	AVR assembly	1	
C18	M9 4006 099	BS460N025P64	ヒューズホルダ	Fuse holder	2	
C19	M9 1001 091	BS460N011P36	ヒューズ	Fuse	2	
C20	M9 5001 093		トランス	Transformer	1	
C21	M9 1001 094		抵抗	Resister	1	
C22	M9 5501 096	TE730P095G10	プリント板組立	PC Board	1	
C23	M9 1007 096		ハルスモータドライバ	Stepping motor driver	1	
C24	M9 0811 050	S913N040P08	平座金 8	Washer 8	4	
C25	M9 0108 053	S913N210P08	バネ座金 8	Spring washer 8	4	
C26	M9 8001 021	S903N212P16	六角穴付ボルト M8×16	Bolt M8×16	4	
C27	M9 5002 093		トランス	Transformer	1	
C28	M9 8001 093		ファン	Fan	1	
C29	M9 7123 099	BE703D266G30	接続電線組立	Cable assembly	1	
C30	M9 8501 096	TE703P187G10	プリント板組立	PC Board	1	
C31	MS 05E0 499	BE731A405G01	箱組立	Box assembly	1	

PLK-2520

# C-2. 操作箱 CONTROLE MECHANISM

PLK-2520

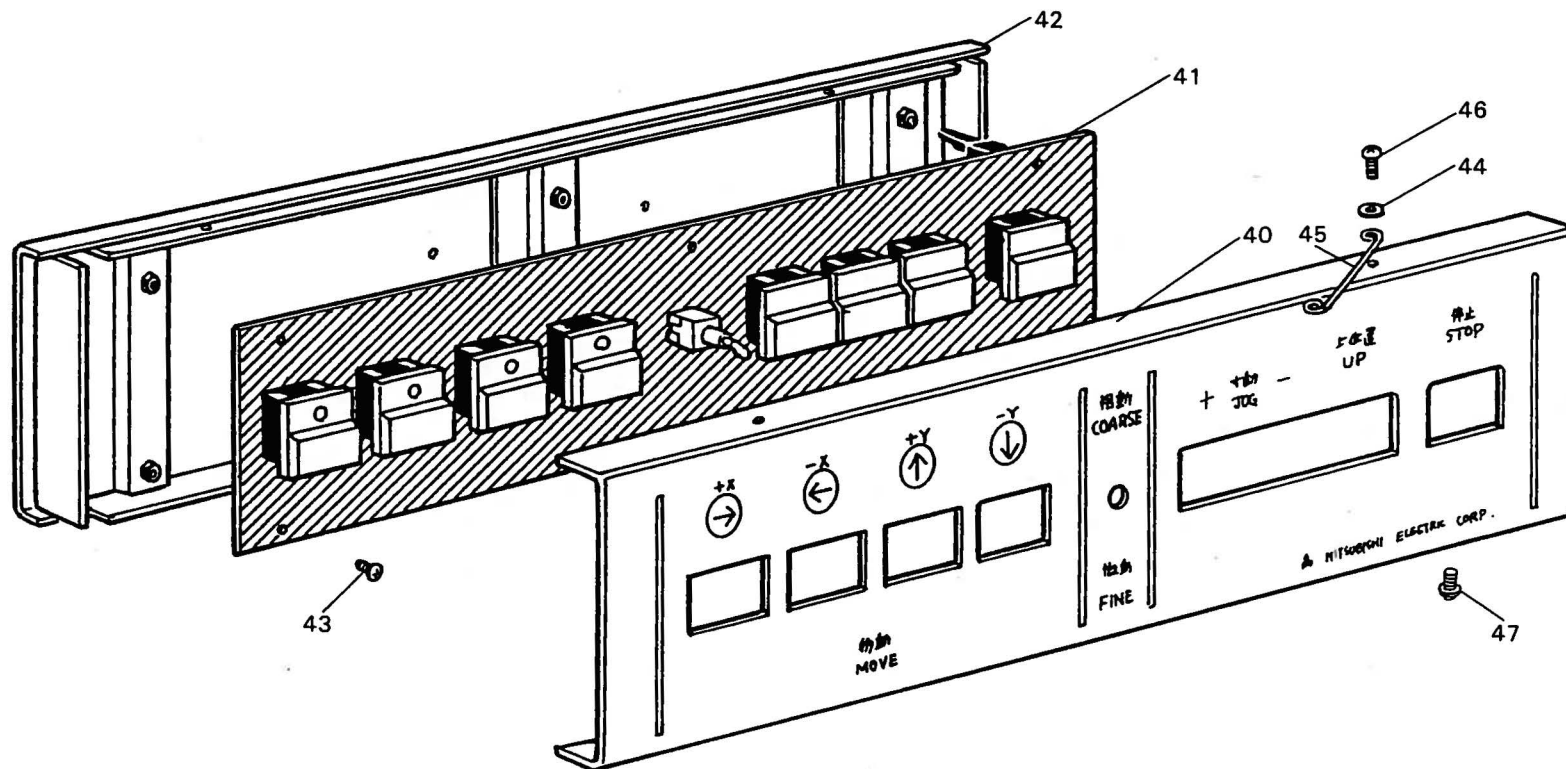

# C-2. 操作箱 CONTROLE MECHANISM

Fig. No.	部品コード Parts. No.	資材コード Ref. No.	部 品 名	Description	使用 個数 Amt. Req.
C40	MS 05A0 742	BE703C464H01	フ タ	Cover	1
C41	M9 7501 096	BE702B084G10	プリント板組立 PPB	PC Board (PPB)	1
C42	MS 05E0 513	BE702B404G30	ハ コ 組 立	Case	1
C43	M9 0304 037	BS902N032P12	SW-PW付Pナベネジ M3×12	SW-PW Screw M3×12	6
C44	M9 0312 050	BS913N040P02	平 座 金 3	Washer	1
C45	MS 05A0 180	BE702D651H01	糸 か け	Thread guide	1
C46	M9 0303 037	BS902N032P10	SW-PW付Pナベネジ M3×10	Screw with SW & PW M3×10	1
C47	M9 0302 037	BS902N032P08	SW-PW付Pナベネジ M3×8	Screw with SW & PW M3×8	3

PLK-2520

C-3. 本体配線  
CONTROLE MECHANISM

PLK-2520

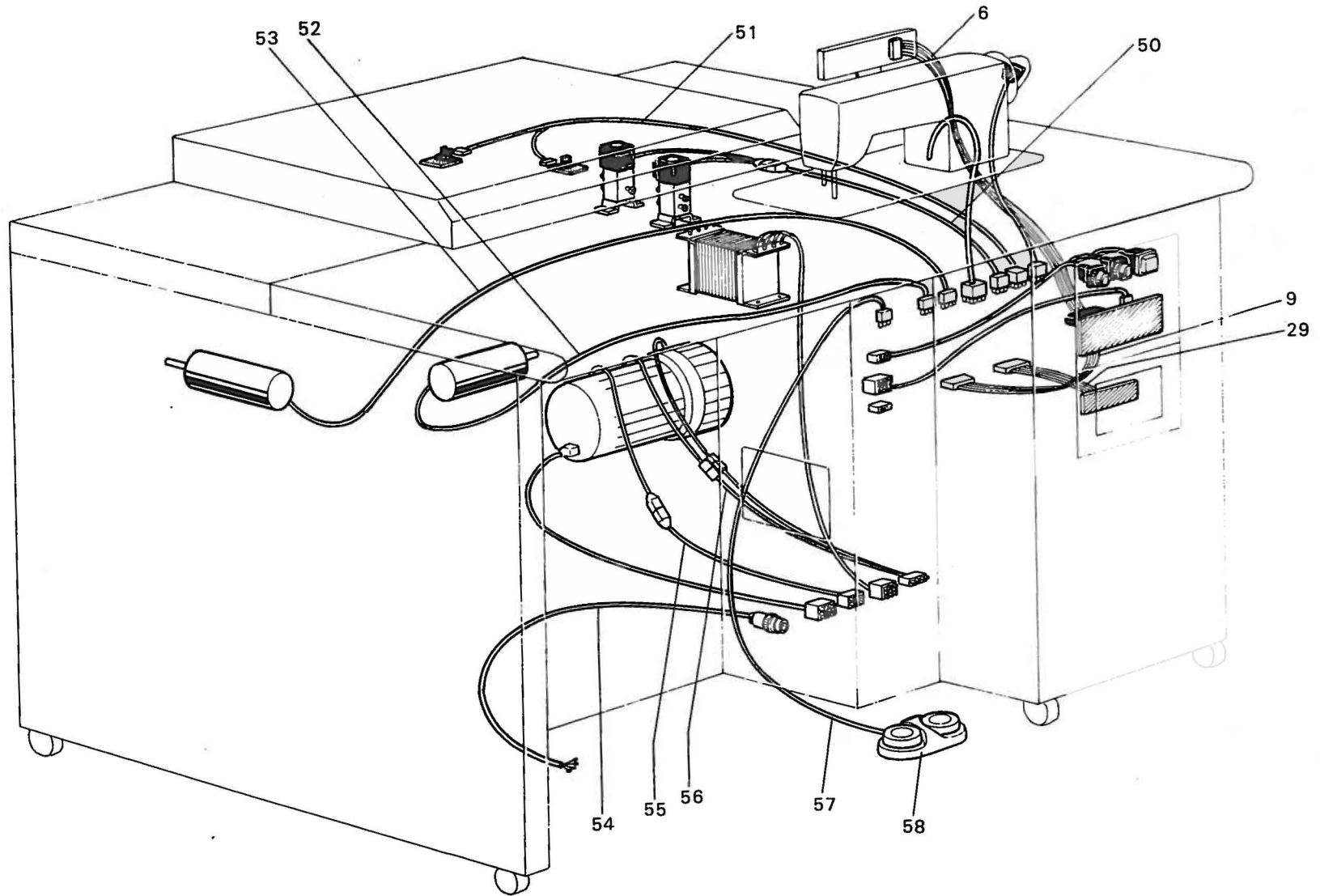

C-3. 本体配線

CONTROLE MECHANISM

Fig No.	部品コード Parts No.	資材コード Ref. No.	部 品 名	Description	使用 個数 Amt. Req.	
C50	M9 7116 099	BE731D250G30	接続電線組立	Cable assembly	1	
C51	M9 7111 099	BE731D262G30	接続電線組立	Cable assembly	1	
C52	M9 7113 099	BE731D254G31	接続電線組立	Cable assembly	1	
C53	M9 7114 099	BE731D254G30	接続電線組立	Cable assembly	1	
C54	M9 7112 099	BE731D260G30	接続電線組立	Cable assembly	1	
C55	M9 7121 099	BE703D252G31	接続電線組立	Cable assembly	1	
C56	M9 7117 099	BV44653G30	接続電線組立	Cable assembly	1	
C57	M9 7115 099	BE731D253G30	接続電線組立	Cable assembly	1	
C58	M9 1001 090		フットスイッチ	Foot switch	1	SFU-1-2

PLK-2520

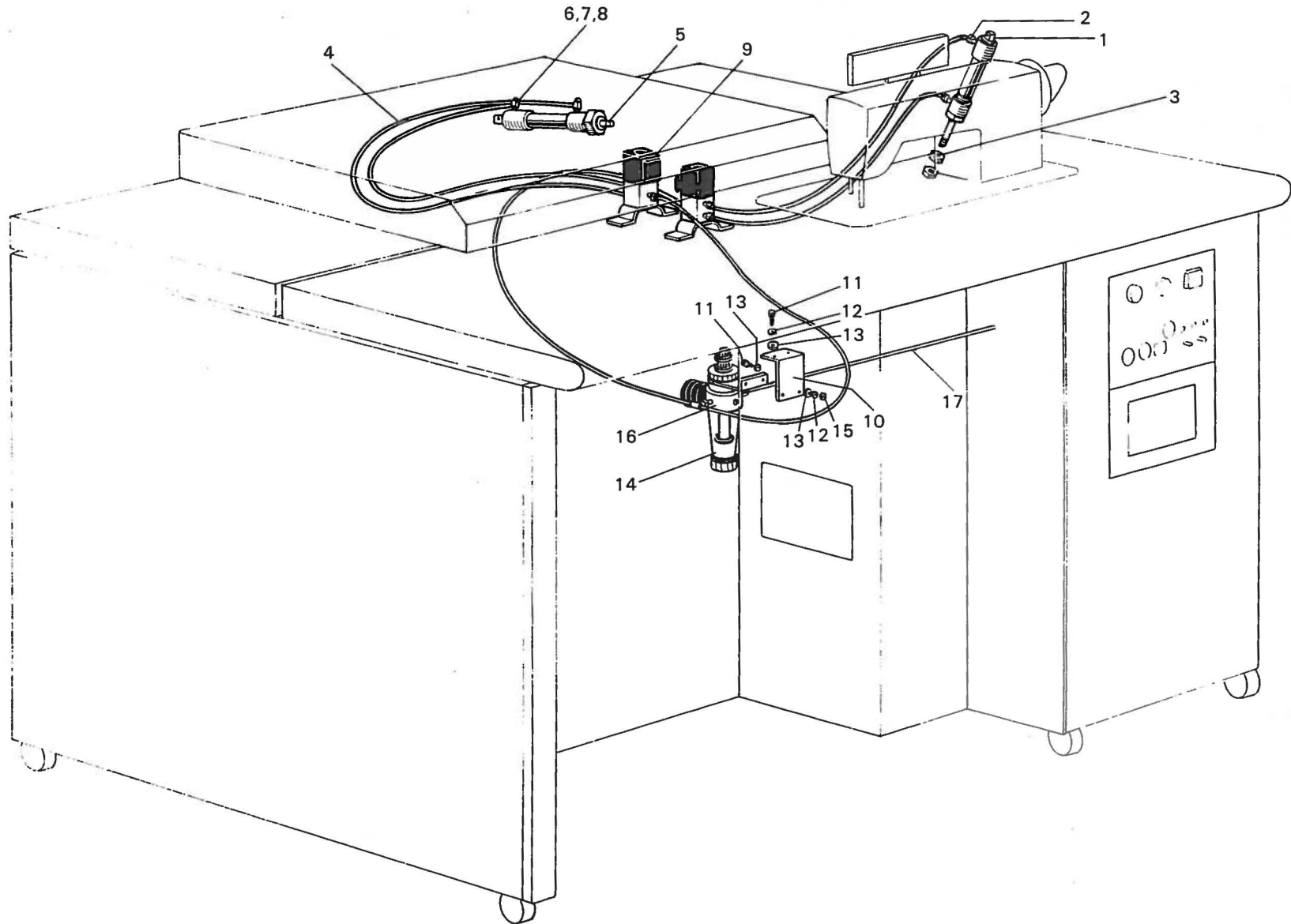

# N. エア関係 AIR MECHANISM

Fig. No.	部品コード Parts. No.	資材コード Ref. No.	部品名	Description	使用 個数 Amt. Req.	
N 1	MS 05E0 434		エアシリンダ	Air cylinder	1	DA-20×25
N 2	MS 05E2 571		クイック継手	Quick joint	2	TS4-01
N 3	M9 2008 045	BS910N010P08	ナット M8 (細目)	Nut M8	2	
N 4	MS 05A2 731		チューブ	Tube	6	ジュンロンAS1 70-04 4×3.15m
N 5	MS 05E1 434		エアシリンダ	Air cylinder	1	DA-20×25Y
N 6			ブッシュ	Fitting	2	RBF
N 7	MS 05E0 571		ユニバーサルエルボ継手	Elbow	2	UEF
N 8			パーブ継手		8	BF5
N 9	M9 1002 093		電磁弁	Solenoid valve	2	050-4E-21-70-DC24V
N10	MS 05A9 601	A130C352H01	取付板 (エアユニット)	Bracket	1	
N11	M9 5003 021	BS903N210P12	六角穴付ボルト M5×12	Bolt M5×12	4	
N12	M9 0501 053	BS913N210P05	バネ座 <sup>1</sup> 金 5	Spring washer 5	4	
N13	M9 8008 050	BS913N040P05	座 金 5	Washer 5	4	
N14	MS 05E0 337		フィルタレギュレータ	Filter-Regulator	1	KFR125-G-02
N15	M9 1373 045	BS910N010P05	ナット 5	Nut 5	2	
N16	MS 05E1 571		ティー継手	Tee	1	TT4-02
N17	MS 05A1 731		チューブ	Tube	1	ジュンロンAS1 70-80 8×6.10m

PLK-2520

F. 付属品・オプションパーツ  
ACCESSORIES ITS OPTION PARTS

PLK-2520





F. 付属品 オプションパーツ  
ACCESSORIES ITS OPTION PARTS

Fig. No.	部品コード Parts. No.	資材コード Ref. No.	部 品 名	Description	使用 個数 Amt. Req.
F 1	MV 30E0 718	E730D001G10	PROMカセットケース	Cassette case with PROM	1
F 2	M9 1001 091	S460N011P36	ヒューズ 10A	Fuse 10A	2
F 3	MS 05A0 608		プラスドライバー ㊦1	Plus driver	1
F 4	M9 0301 037	S902N032P06	SW-PW付Pナベネジ M3×6	Screw M3×6	40
F 5	M9 0302 037	S902N032P08	// M3×8	// M3×8	60
F 6	MS 05A1 976	S689N902P07	六角棒レンチ 6	Socket wrench 6	1
F 7	MS 05A0 976	S689N902P06	// 5	// 5	1
F 8	MS 01A1 976	S689N902P05	// 4	// 4	1
F 9	MS 01A0 976	S689N902P04	// 3	// 3	1
F10	MS 05A0 254	A120B104G30	上 押 之 板 (1)	Upper clamp frame (1)	3
F11	MS 05A1 254	A120B105G01	// (2)	// // // (2)	3
F12	MV 30A0 602	E702C595H02	取 付 金 具 (1)	Holding plate	10
F13	MV 30A1 602	E702D596H02	// (2)	//	8
F14	MV 30A2 601	E702D597H01	取 付 板	//	20
F15	MS 05A0 257	A120B106G30	下 押 之 板 (1)	Lower clamp frame (1)	2
F16	MS 05A1 257	A120B107G01	// (2)	// // // (2)	1
F17	MS 05A0 762	A120B108G01	// (樹脂)	// // //	2
F18	MV 35A0 762	E702C397H01	中 押 之 板 260×225×2t	Foamed polyethylene plate 260×225×2t	10
F19	MV 35A1 762	E702C397H02	// 260×160×2t	// // // 260×160×2t	4
F20	MV 35A2 762	E702C397H03	// 260×225×1t	// // // 260×225×1t	3
F21	MV 35A0 257	E702B342H01	押 之 板 (樹脂) 300×300×1t	Presser plate 300×300×1t	4
F22	MV 35A1 257	E702B342H02	// // // ×2t	// // // 300×300×2t	2
F23	MV 35A0 106	A130C274H01	平 押 之	Presser foot (flat)	オプション

MEMO

PLK-2520

